

USER MANUAL

MODEL:

KDS-8-MNGR
SDVoE Manager



KRAMER



Contents

Introduction	1
Getting Started	1
Overview	3
System Requirements	3
Typical Applications	4
Defining KDS-8-MNGR	5
Front and Back Panel	5
Connecting KDS-8-MNGR	7
RS-232 Pinout and Defaults	8
Operating via Ethernet	8
Using Embedded Web Pages	11
Discovering IP Address	13
Monitoring and Controlling Decoders and Encoders	14
Configuring the System	30
Configuring System Settings	33
Configuring Transmitters	45
Configuring Receivers	47
Defining Output Resolution	49
Configuring Video Walls	50
Configuring Multiviews	51
Technical Specifications	54
Default Communication Parameters	55
Video Specifications	55
Acronyms	57
Telnet Control	58
RS-232 and Telnet Commands	58

Introduction

Welcome to Kramer Electronics! Since 1981, Kramer Electronics has been providing a world of unique, creative, and affordable solutions to the vast range of problems that confront the video, audio, presentation, and broadcasting professional on a daily basis. In recent years, we have redesigned and upgraded most of our line, making the best even better!



In this user manual, **KDS-8** refers also to **KDS-8F**.

Getting Started

We recommend that you:

- Unpack the equipment carefully and save the original box and packaging materials for possible future shipment.
- Review the contents of this user manual.



Go to www.kramerav.com/downloads/KDS-8-MNGR to check for up-to-date user manuals, application programs, and to check if firmware upgrades are available (where appropriate).

Achieving Best Performance

- Use only good quality connection cables (we recommend Kramer high-performance, high-resolution cables) to avoid interference, deterioration in signal quality due to poor matching, and elevated noise levels (often associated with low quality cables).
- Do not secure the cables in tight bundles or roll the slack into tight coils.
- Avoid interference from neighboring electrical appliances that may adversely influence signal quality.
- Position your Kramer **KDS-8-MNGR** away from moisture, excessive sunlight and dust.

Safety Instructions



Caution:

- This equipment is to be used only inside a building. It may only be connected to other equipment that is installed inside a building.
- For products with relay terminals and GPIO ports, please refer to the permitted rating for an external connection, located next to the terminal or in the User Manual.
- There are no operator serviceable parts inside the unit.



Warning:

- Use only the power cord that is supplied with the unit.
- To ensure continuous risk protection, replace fuses only according to the rating specified on the product label which is located on the bottom of the unit.

Recycling Kramer Products

The Waste Electrical and Electronic Equipment (WEEE) Directive 2002/96/EC aims to reduce the amount of WEEE sent for disposal to landfill or incineration by requiring it to be collected and recycled. To comply with the WEEE Directive, Kramer Electronics has made arrangements with the European Advanced Recycling Network (EARN) and will cover any costs of treatment, recycling and recovery of waste Kramer Electronics branded equipment on arrival at the EARN facility. For details of Kramer's recycling arrangements in your particular country go to our recycling pages at www.kramerav.com/support/recycling.

Overview

Congratulations on purchasing your Kramer **KDS-8-MNGR SDVoE Manager** (Software Defined Video over Ethernet Manager). **KDS-8-MNGR** Manager is the solution for configuration and management of **KDS-8** and **KDS-8F** deployments within the same network. Just install the unit into the same local network as the extenders (encoders and decoders) to easily define and configure channel routing selections (including video, audio, and a variety of control interface types) using the embedded web pages. Without the use of this centralized control unit, each encoder/decoder pair would only function in a point-to-point capacity.

Additionally, this unit supports controlling and configuring the matrix, video wall, and multiviewer modes of connected **KDS-8** devices. The settings of all connected encoder/decoder units, including IP configuration, compatibility settings, and extender status are clearly displayed and easily managed in the embedded web pages.

A trigger input interface is also provided to allow the easy addition of a Kramer Control remote keypad, or other trigger-supporting products, which can be installed within a podium or table in a conference room or classroom. This interface can allow the user to activate stored macros with the simple press of a button. Standard control is available via the embedded web pages (remote or local), RS-232, Telnet and IR Remote.

KDS-8-MNGR provides exceptional quality and user-friendly operation:

- Centralized Management – Manage and configure multiple compatible **KDS-8** devices through a single web interface. Control the independent routing of video, audio and control signals. Configure matrix, video wall, and multiviewer modes.
- Customizable – Create macros to further streamline and customize operation of the connected devices.
- Status at-a-Glance – Displays the status of all connected Transmitters and Receivers, including IP addresses, channel selections, and more.
- Serial Control – Generates serial commands to directly control an external serial-controlled device.
- Flexible Power – Can be powered by Ethernet switches supporting the IEEE 802.3af 2003 PoE standard (optional).
- Convenient Control Options – Standard control is available via embedded web pages (remote or local), RS-232, and Telnet.

System Requirements

Operating the **KDS-8-MNGR**, requires an active network connection from a switch or router for control of compatible AV over IP devices.

Typical Applications

KDS-8-MNGR is ideal for the following typical applications:

- Video/TV wall display and control.
- Security surveillance and control.
- Commercial advertising, display and control.
- Home theaters with smart home controls.
- Retail sales and demonstration.

Defining KDS-8-MNGR

Front and Back Panel

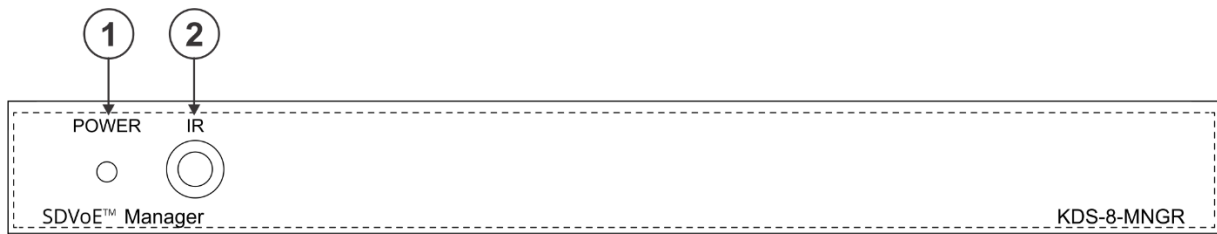

Figure 1: KDS-8-MNGR SDVoE Manager Front Panel

#	Feature	Function
①	POWER LED	Lights when the device receives power.
②	IR Window	N/A

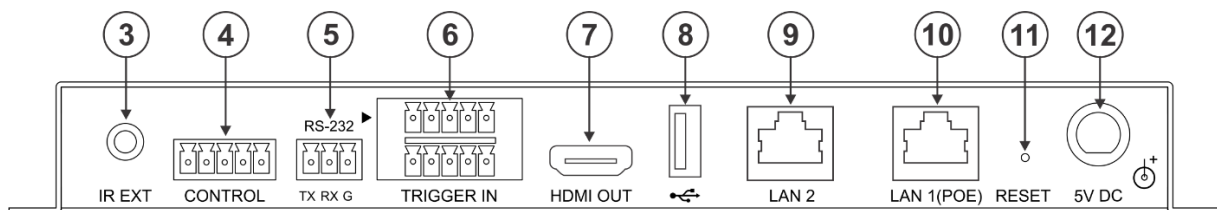

Figure 2: KDS-8-MNGR SDVoE Manager Rear Panel

#	Feature	Function
③	IR EXT Port	For future use.
④	CONTROL 5-pin Terminal Block	For future use.
⑤	RS-232 3-pin Terminal Block	Connect to a PC, laptop or other serial control device with a 3-pin adapter cable to control the unit via RS-232.
⑥	TRIGGER IN 10-pin Terminal Block	Connect to the Trigger Control Keypad (OPTIONAL) or any device with trigger switch functionality such as window security alarms, motion detectors, door switches, etc. Each of the 8 trigger inputs will activate the associated macro (1~8) when triggered. i A minimum of 5V DC is required to activate each trigger.
⑦	HDMI™ OUT Port	Connect to a standard HDMI display to view the unit current status information and access the embedded web pages directly without a PC. i HDMI output is locked to a resolution of 1080p@60Hz.
⑧	USB Port	Connect a USB mouse and keyboard to control the unit's embedded web pages that are displayed on the HDMI output port. Firmware update via USB is also supported. i Specialized USB control devices, such as a touch panel, should be connected before the unit is powered on.
⑨	LAN 2 Port	Connect directly, or through a network switch, to your PC/ laptop to control the unit via embedded web pages/Telnet.

#	Feature	Function
⑩	LAN 1(PoE) Port	<p>Connect to the SDVoE units' 10G Network through dedicated network switch, to enable detection and control over those units.</p> <p>i If the connected network switch supports the IEEE 802.3af 2003 PoE (Power over Ethernet) standard, KDS-8-MNGR can optionally be powered directly via this Ethernet port.</p>
⑪	FACTORY RESET	<p>Press and hold for 3 seconds to reset the unit to its factory defaults, including Ethernet settings.</p> <p>i While the reset is in process, the front panel LEDs flash. Once the reset is complete, the unit returns to normal operation.</p>
⑫	5V DC Port	<p>Plug the 5V DC power adapter into the unit and connect it to an AC wall outlet for power. (Optional, not required if the unit is powered via PoE).</p>

Connecting KDS-8-MNGR

- i** Always switch off the power to each KDS-8 device before connecting it to your KDS-8-MNGR. After connecting your KDS-8-MNGR, connect its power and then switch on the power to each device.

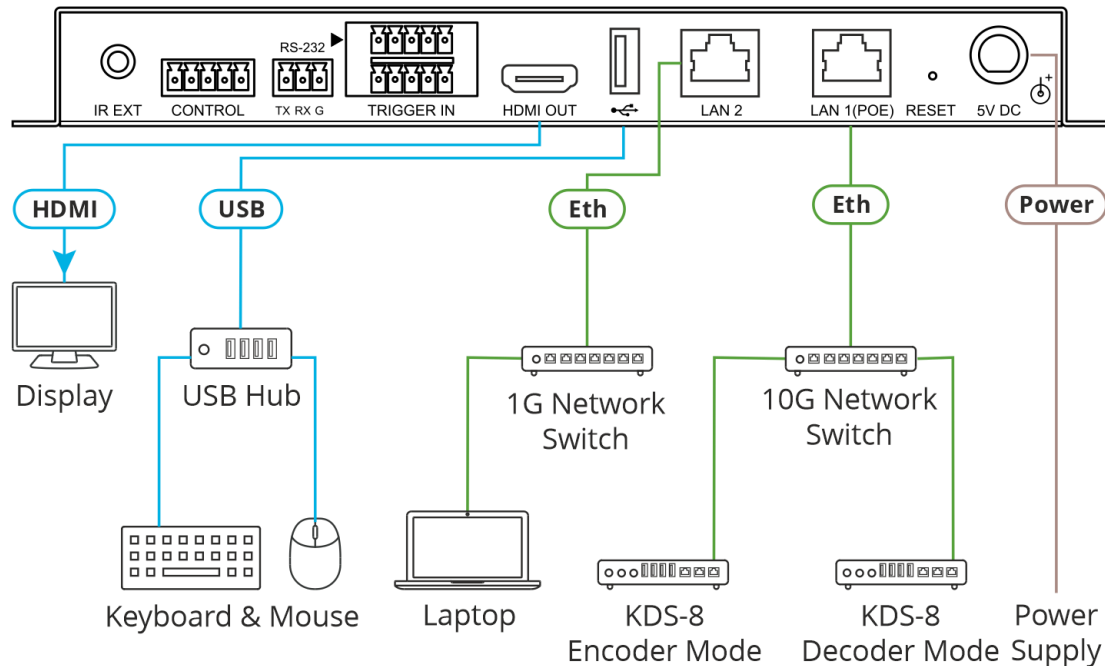

Figure 3: Connecting to the KDS-8-MNGR

To connect KDS-8-MNGR as illustrated in the above example:

1. Connect an HDMI acceptor to the HDMI OUT connector (7).
2. Connect the USB port to a USB Hub (8) that is connected to a keyboard and mouse.
3. Connect Ethernet LAN 2 RJ-45 connector (9) to a 1G Network switch that is connected to a laptop.
Alternatively, you can connect LAN 2 directly to a laptop.
4. Connect Ethernet LAN 1 (PoE) RJ-45 Connector (10) to a 10G Network switch that is connected to KDS-8 (or KDS-8F) encoders and decoders.
5. Connect the 5V DC connector (12) power adapter to the device and the mains electricity.

- i** If the unit is powered via PoE (PD) there is no need to connect the power adapter.

RS-232 Pinout and Defaults

Serial Port Default Settings	
Baud Rate	19200
Data Bits	8
Parity Bits	None
Stop Bits	1
Flow Control	None

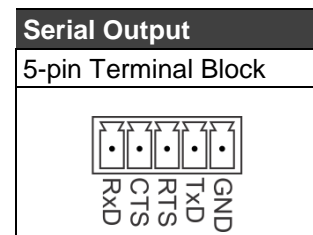
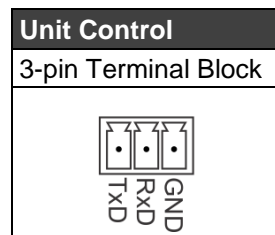

Operating via Ethernet

You can connect to **KDS-8-MNGR** via Ethernet using either of the following methods:

- Directly to the PC using a crossover cable (see [Connecting Ethernet Port Directly to a PC](#) on page 8).
- Via a network hub, switch, or router, using a straight-through cable (see [Connecting Ethernet Port via a Network Hub](#) on page 10).



If you want to connect via a router and your IT system is based on IPv6, speak to your IT department for specific installation instructions.

Connecting Ethernet Port Directly to a PC

You can connect the Ethernet port of **KDS-8-MNGR** directly to the Ethernet port on your PC using a crossover cable with RJ-45 connectors.



This type of connection is recommended for identifying **KDS-8-MNGR** with the factory configured default fallback IP address.

After connecting **KDS-8-MNGR** to the Ethernet port, configure your PC as follows:

1. Click **Start > Control Panel > Network and Sharing Center**.
2. Click **Change Adapter Settings**.
3. Highlight the network adapter you want to use to connect to the device and click **Change settings of this connection**.

The Local Area Connection Properties window for the selected network adapter appears as shown in [Figure 4](#).

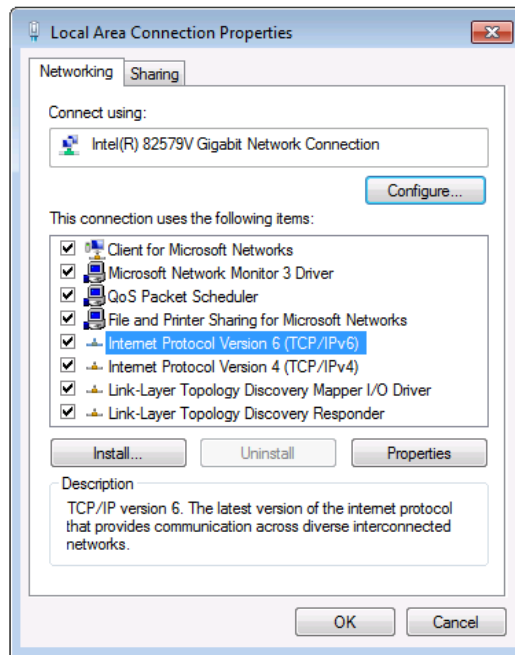

Figure 4: Local Area Connection Properties Window

4. Highlight either **Internet Protocol Version 6 (TCP/IPv6)** or **Internet Protocol Version 4 (TCP/IPv4)** depending on the requirements of your IT system.
5. Click **Properties**.

The Internet Protocol Properties window relevant to your IT system appears as shown in [Figure 5](#) or [Figure 6](#).

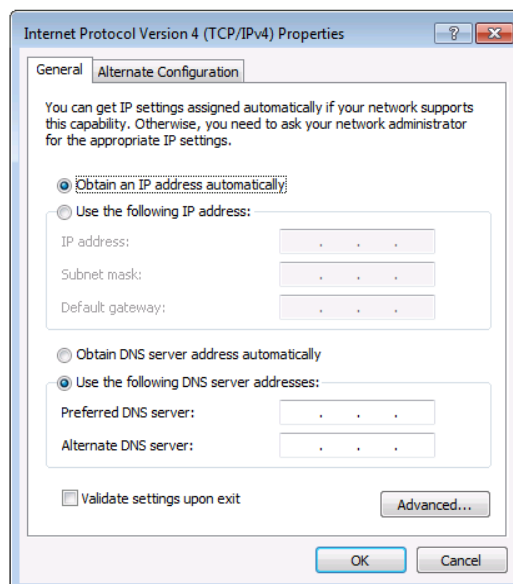

Figure 5: Internet Protocol Version 4 Properties Window

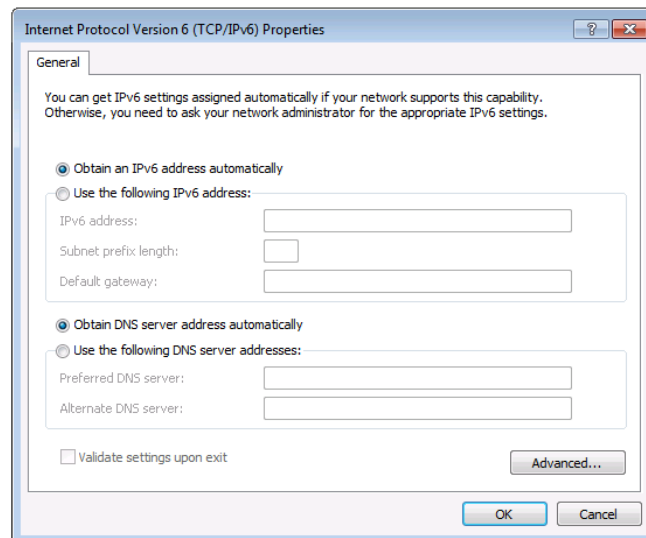

Figure 6: Internet Protocol Version 6 Properties Window

6. Select **Use the following IP Address** for static IP addressing and fill in the details as shown in [Figure 7](#).

For TCP/IPv4 you can use any IP address in the range 192.168.1.1 to 192.168.1.255 (excluding 192.168.1.39).

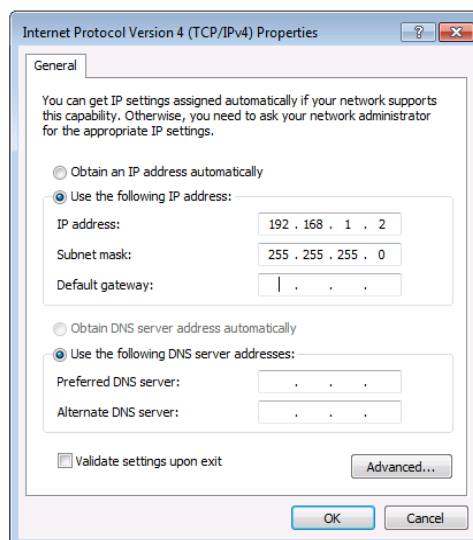

Figure 7: Internet Protocol Properties Window

7. Click **OK**.
8. Click **Close**.

Connecting Ethernet Port via a Network Hub or Switch

You can connect the Ethernet port of **KDS-8-MNGR** to the Ethernet port on a network hub or using a straight-through cable with RJ-45 connectors.

Configuring Ethernet Port

You can set the Ethernet parameters via the embedded Web pages.

Using Embedded Web Pages

KDS-8-MNGR can be operated and controlled remotely using the embedded Web pages. The Web pages are accessed using a Web browser and an Ethernet connection. By default, **KDS-8-MNGR** is set to DHCP.

Before attempting to connect:

- If required, discover the device IP Address (see [Discovering IP Address](#) on page [13](#)).
- Perform the procedures in [Operating via Ethernet](#) on page [8](#).
- Ensure that your browser is supported.

The following operating systems and Web browsers are supported:

Operating Systems	Browser
Windows 10	Chrome (Recommended)
	Firefox
Mac	Safari
iOS	Safari
Android	Chrome



Some features might not be supported by some mobile device operating systems.

KDS-8-MNGR enables performing the following:

- [Discovering IP Address](#) on page [13](#).
- [Monitoring and Controlling Decoders and Encoders](#) on page [14](#).
- [Configuring the System](#) on page [30](#).
- [Configuring System Settings](#) on page [33](#).
- [Configuring Transmitters](#) on page [45](#).
- [Configuring Receivers](#) on page [47](#).
- [Defining Output Resolution](#) on page [49](#).
- [Configuring Video Walls](#) on page [50](#).
- [Configuring Multiviews](#) on page [51](#).

To use the browser:

1. Open your Internet browser.
2. Type the IP number of the device, or its hostname, in the Address bar of your browser.
For example,:

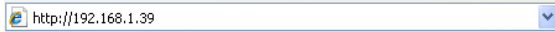

The device operation page appears.

After connecting to the embedded pages address in a web browser, the embedded pages load and display the System tab.

To Access the embedded web pages:

1. Click **Login** to open the authentication window.
2. Enter the appropriate User Name and Password (admin) and click **Enter**.
If a keyboard is not available, such as when using a touch screen, an on-screen keyboard can be activated by clicking on the keyboard icon (⌨).



The default user name and password is admin.

AV over IP Controller

192.168.1.50

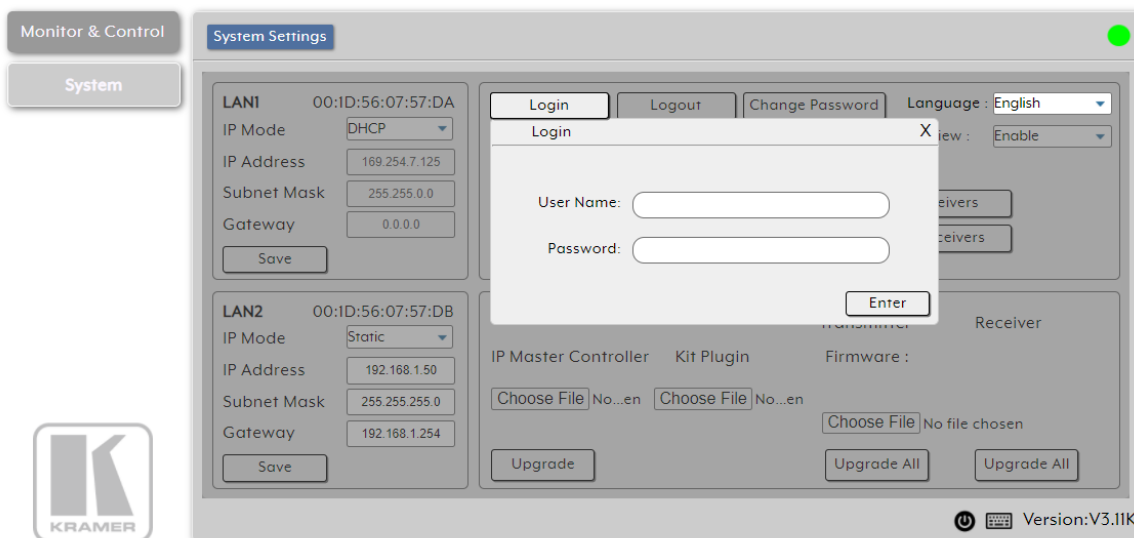

Figure 8: Accessing the Embedded Web Pages

Once you are logged-in, the menu tabs appear to the left of each page.



Figure 9: Menu Tabs

To logout:

1. In the System tab click **Logout**.



When not logged in, only the Monitor & Control and System tabs are available.

Discovering IP Address

You can discover the IP address either by connecting and then sending RS-232 commands via the **KDS-8-MNGR** RS-232 port (see [RS-232 and Telnet Commands](#) on page 58), or via the HDMI output.

To discover or change the IP address via HDMI output:

1. Connect the **KDS-8-MNGR** HDMI output to a display. The System tab in the offline embedded web pages appears (only Monitor & Control and System tabs are displayed offline).
2. View the IP address or change it as follows:
 - a. Connect a mouse to the USB port on the rear panel.
 - b. Click  to open a keyboard on-screen to enter text.
 - c. Click **Login**. The Login window appears.

Figure 10: Login Window

- d. Click mouse in User Name text box. On-screen keyboard opens.
 - e. Enter the User Name (admin, by default).
 - f. Move cursor to Password text box.
 - g. Enter the Password (admin, by-default).
 - h. Click **Enter**.
3. Change Network settings as desired.



Discovered IP address can be used to access embedded web pages online.

Monitoring and Controlling Decoders and Encoders

The Monitor & Control tab provides easy to use drag-and-drop control over all basic routing functions of the **KDS-8** encoders and decoders that have been detected within the local network and enables performing the following actions:

- [Routing Video](#) on page [15](#).
- [Routing a Video Wall](#) on page [17](#).
- [Routing a Multi-viewer](#) on page [18](#).
- [Routing HDMI Audio](#) on page [19](#).
- [Routing Analog Audio](#) on page [22](#).
- [Pairing USB Hosts and Devices](#) on page [24](#).
- [Routing IR Signals](#) on page [26](#).
- [Routing RS-232 Signals](#) on page [27](#).
- [Activating a Macro](#) on page [29](#).



In all the sections (except for the Routing Video section), transmitters (encoders) are represented by the source icon () and receivers (decoders) are represented by the display icon (). Each of this tab's sections control the routing of a different type of interface of **KDS-8** and **KDS-8F**.

Units that were previously a part of the system, but are not currently detected will still be displayed, however they will have a disconnected icon () and cannot be used for routing.

Routing Video

Drag and drop detected encoders and decoders to control video routing in the system.

The Video page includes two main areas. The:

- **Video Transmitter** area, which includes drag-and-drop depiction buttons for all the encoders that are detected by the system, and a multi-option stop button to stop video transmission.
- **Video Receiver** area, which includes drag-and-drop depiction buttons for all the decoders that are detected by the system, and a Stop button to stop one or all output streams from being displayed.

Each encoder and decoder box is depicted as a small-sized, low-framerate, video thumbnail indicating which video is currently active, or can be represented as follows to indicate that:



The encoder is in the video wall mode.



The encoder is in the Multiviewer mode.



The encoder current input has no live source connected.



The decoder does not have an active display connected.



The encoder/decoder does not support the video thumbnail feature.



The encoders' source streams are collectively exceed the 10Gbps bandwidth limitation.



The encoder/decoder is offline or currently not detected by **KDS-8-MNGR**.



KDS-8-MNGR features automatic bandwidth reduction if the total source streaming exceeds 10Gbps. In case this happens, we recommend that you reduce the source resolution, frame rate or bit depth to maintain stable video quality on the display.

The Video page enables performing the following actions:

- [Streaming an HDMI Audio Source to a Single Decoder](#) on page [20](#).
- [Streaming an HDMI Audio Source to Multiple Decoders](#) on page [21](#).
- [Stopping an HDMI Audio Source Stream](#) on page [21](#).
- [Stopping an HDMI Audio Display Stream](#) on page [21](#).

Streaming a Source to a Single Decoder

To route a source (on a detected encoder) to a display on an encoder:

1. In the Menu tabs, select Monitor & Control. The Video page appears.

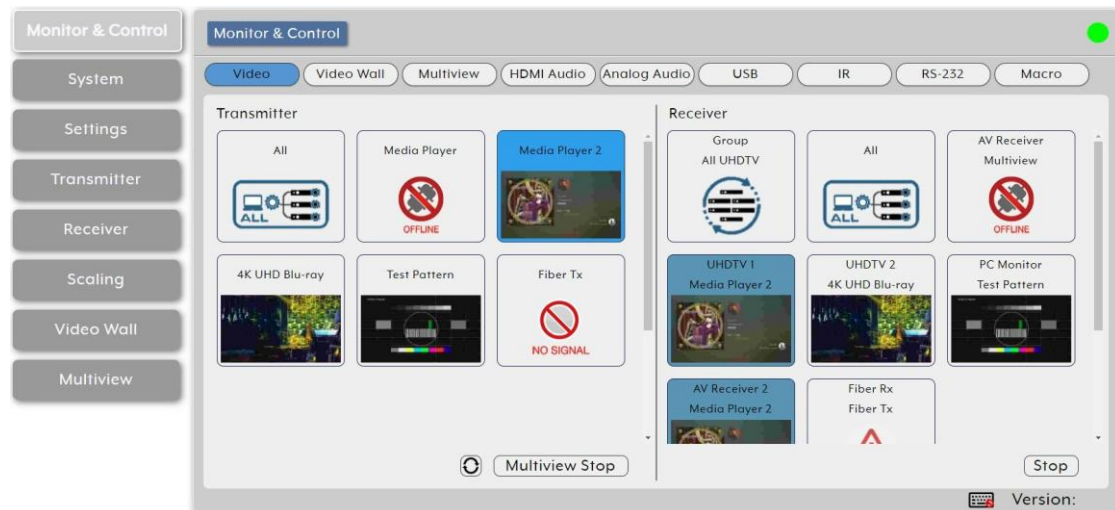

Figure 11: Monitor & Control Tab – Video Page

2. Click and drag a source button in the transmitter area to the preferred display in the receiver area.
3. Release the mouse button.
The routed source name appears below the display name.
The selected source and routed displays change their color.



You can also drag and drop display decoders to an encoder source on the transmitter side to activate a new streaming route.

The source on the encoder is streamed to the decoder.

Streaming a Source to Multiple Decoders

To route a source (on a detected encoder) to multiple encoders:

1. In the Menu tabs, select Monitor & Control. The Video page appears.
2. Click and drag a source button in the transmitter area to a predefined Video group or an All button in the receiver area.
3. Release the mouse button.
The routed source name appears below the group name.

The source on the encoder is streamed to multiple decoders.

Stopping a Video Source Stream

You may need to stop one or all the video streams coming from a source.

To stop a video source stream:

1. In the Menu tabs, select Monitor & Control. The Video page appears.
2. Click  (Stop selection button) at the lower part of the transmitter area and cycle to the required option:
 - **All Stop** stops all stream types from the selected source.
 - **Native Stop** stops only the full resolution primary video stream.
 - **Multiview Stop** stops only the secondary video stream used by multiviewer layouts.
3. Click and drag the source to the selected Stop button. Streaming from that source stops.



To stop a stream type from ALL video streams simultaneously, drag **All** down to the All Stop button.

Source/s streaming has stopped.

Stopping a Video Display Stream

To stop a video display stream:

1. In the Menu tabs, select Monitor & Control. The Video page appears.
2. Click and drag the display to the Stop button.
3. Release the mouse. Streaming to that display stops.



Drag **All** button down to the Stop button to stop all streaming.

Display streaming has stopped.

Routing a Video Wall

Drag and drop detected encoder sources and decoder displays to control predefined video wall routing in the system. Go to [Configuring Video Walls](#) on page [50](#) to define a video wall group.

The Video Wall section includes three main areas. The:

- **Group** area, which includes all the currently defined video wall groups Click a group icon to display a simplified graphical representation of the video wall on the video wall view on the right side of the page. For example, Video Wall 1 group shows as Group: Video Wall 1 on the right side of the Video wall section.
- **Transmitter** area, which includes all the available decoders.
- **Video wall view** area, representing the selected video wall.

To assign a source to a video wall group:

1. In the Menu tabs, select Monitor & Control. The Video section appears.
2. Click **Video wall**. The Video Wall section appears.

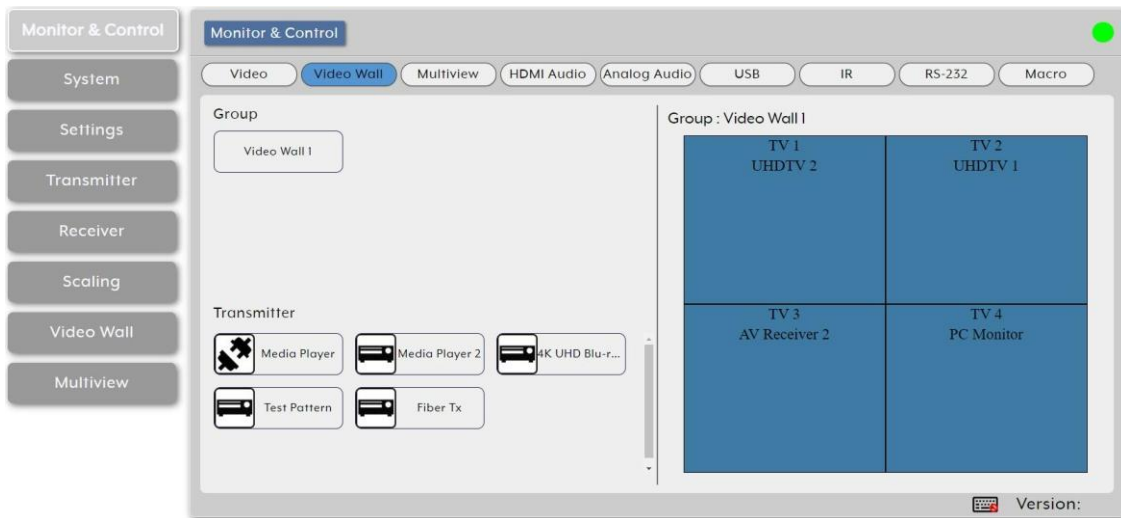

Figure 12: Monitor & Control Tab – Video Wall Page

3. Drag a source from the Transmitter area to the required video wall group.

The source on the encoder is streamed to the Video Wall.



Dragging a source to an inactive video wall group, automatically activates all of that video wall displays.

Routing a Multi-viewer

Set the streaming in a multi-viewer by dragging and dropping the Multiview preset to an available decoder display and also by dragging and dropping a decoder source over to Multiview windows.

Before routing inputs to Multiview windows, you need to define a Multiview preset (see [Configuring Multiviews](#) on page 51).

The Multiview page includes four main areas. The:

- **Preset** area, which includes all currently defined multiview presets.
- **Receiver** area, which includes all the decoder displays that available to display the multiview preset.
- **Multiviewer view** area, which shows a simplified graphical representation of the currently selected multiview preset. An active preset appears has green windows that show a faded video thumbnail of the source that is currently selected.
- **Transmitter** area, which includes all the encoder sources. Unavailable sources are displayed in red.

To assign a source to a Preset Multiviewer:

1. In the Menu tabs, select Monitor & Control. The Video section appears.
2. Click **Multiview**. The Video Wall section appears.



Figure 13: Monitor & Control Tab – Multiview Section

3. From the Preset list, select a Multiview preset (for example, Multiview 1) and drag the selected preset to a selected decoder display (or to all the available displays), listed under Receiver (for example, UHDTV 1).

The multiview preset windows are displayed on the right-side of the page (green windows).

4. From the transmitter list of available encoder sources, drag a source to a window as needed.



Note that a single source cannot be simultaneously displayed in differently sized windows or in multiple presets at different output resolutions.

5. Select a source for each of the Multiview windows.

The sources on the encoders are streamed to the Multiview windows.

Routing HDMI Audio

You can route the HDMI audio signal independently via drag-and-drop of the detected encoders and decoders.



Bitstream audio is supported when the decoder HDMI audio device is set to “HDMI Audio (Follow Video in Genlock Mode)”.

The HDMI Audio page includes two main areas. The:

- **HDMI Audio Transmitter** area, which includes drag-and-drop buttons for all the encoder sources that are detected by the system, and a multi-option stop button to stop video transmission.

- **HDMI Audio Receiver** area, which includes drag-and-drop buttons for all the decoder displays that are detected by the system, and a Stop button to stop one or all audio streams from being displayed.

The HDMI Audio page enables performing the following actions:

- [Streaming an HDMI Audio Source to a Single Decoder](#) on page 20.
- [Streaming an HDMI Audio Source to Multiple Decoders](#) on page 21.
- [Stopping an HDMI Audio Source Stream](#) on page 21.
- [Stopping an HDMI Audio Display Stream](#) on page 21.

Streaming an HDMI Audio Source to a Single Decoder

To route an HDMI audio source (on a detected encoder) to a display on an encoder:

1. In the Menu tabs, select Monitor & Control. The Video page appears.
2. Click **HDMI Audio**. The HDMI Audio page appears.

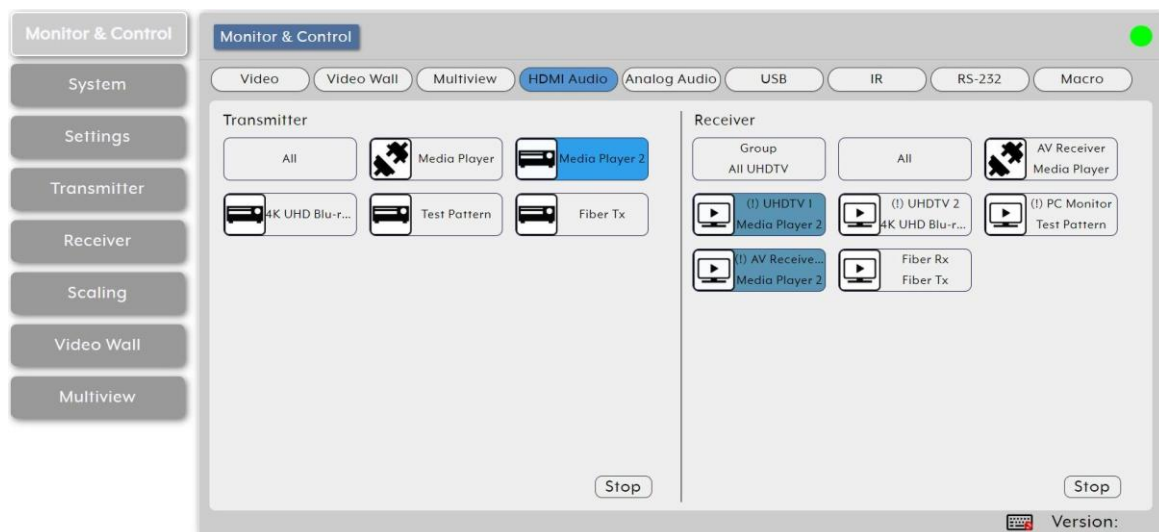

Figure 14: Monitor & Control Tab – HDMI Audio Page

3. Click and drag a source button in the transmitter area to the preferred display in the receiver area.
4. Release the mouse button.
The routed source name appears below the display name.
The selected source and routed displays change their color.



You can also drag and drop display decoders to an encoder source on the transmitter side to activate a new streaming route.

The source on the encoder is streamed to the decoder.

Streaming an HDMI Audio Source to Multiple Decoders

To route an HDMI audio source (on a detected encoder) to multiple encoders:

1. In the Menu tabs, select Monitor & Control. The Video page appears.
2. Click **HDMI Audio**. The HDMI Audio page appears.
3. Click and drag a source button in the transmitter area to a predefined HDMI audio group or an All button in the receiver area.
4. Release the mouse button.
The routed source name appears below the group name.

The source on the encoder is streamed to multiple decoders.

Stopping an HDMI Audio Source Stream

You may need to stop one or all the video streams coming from a source.



When the HDMI Audio of an encoder is set to “Follow Video in Genlock Mode”, and scaling on that output has been disabled (Bypass), the audio output on that receiver cannot be stopped by using this control.

To stop a HDMI audio source stream:

1. In the Menu tabs, select Monitor & Control. The Video page appears.
2. Click **HDMI Audio**. The HDMI Audio page appears.
3. Click and drag an HDMI audio source button (or the All button) to the Stop button in the transmitter area. Streaming from that source stops.

Source/s streaming has stopped.

Stopping an HDMI Audio Display Stream

To stop an HDMI audio stream on a display:

1. In the Menu tabs, select Monitor & Control. The Video page appears.
2. Click **HDMI Audio**. The HDMI Audio page appears.
3. Click and drag the display to the Stop button.
4. Release the mouse. Streaming to that display stops.



Drag **All** button down to the Stop button to stop all streaming.

Display streaming has stopped.

Routing Analog Audio

You can route analog audio signals via drag-and-drop of the detected encoders and decoders.



Bitstream audio is supported when the decoder HDMI audio device is set to “HDMI Audio (Follow Video in Genlock Mode)”.

The Analog Audio page includes two main areas. the:

- **Analog Audio Transmitter** area, which includes drag-and-drop buttons for all the encoder sources that are detected by the system, and a multi-option stop button to stop video transmission.
- **Analog Audio Receiver** area, which includes drag-and-drop buttons for all the decoder displays that are detected by the system, and a Stop button to stop one or all audio streams from being displayed.



If a selected audio source for an analog output is set to “HDMI Audio (Stereo Downmix)” that output will be marked with an exclamation mark (!) and the audio output will mirror the source set on the HDMI Audio routing page.

The Analog Audio page enables performing the following actions:

- [Streaming an Analog Audio Source to a Single Decoder](#) on page [23](#).
- [Streaming an Analog Audio Source to Multiple Decoders](#) on page [23](#).
- [Stopping an Analog Audio Source Stream](#) on page [24](#).
- [Stopping an HDMI Audio Display Stream](#) on page [24](#).

Streaming an Analog Audio Source to a Single Decoder

To route an analog audio source (on a detected encoder) to a display on an encoder:

1. In the Menu tabs, select Monitor & Control. The Video page appears.
2. Click **Analog Audio**. The Analog Audio page appears.

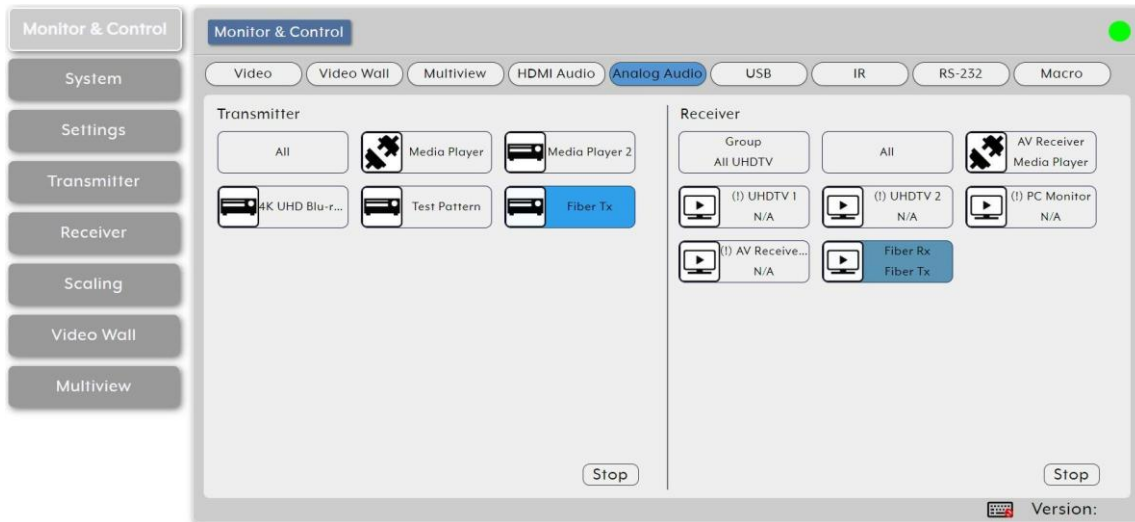

Figure 15: Monitor & Control Tab – Analog Audio Page

3. Click and drag a source button in the transmitter area to the preferred display in the receiver area.
4. Release the mouse button.
The routed source name appears below the display name.
The selected source and routed displays change their color.



You can also drag and drop display decoders to an encoder source on the transmitter side to activate a new streaming route.

The source on the encoder is streamed to the decoder.

Streaming an Analog Audio Source to Multiple Decoders

To route an analog audio source (on a detected encoder) to multiple encoders:

1. In the Menu tabs, select Monitor & Control. The Video page appears.
2. Click **Analog Audio**. The HDMI Audio page appears.
3. Click and drag a source button in the transmitter area to a predefined HDMI audio group or an All button in the receiver area.
4. Release the mouse button.
The routed source name appears below the group name.
The source on the encoder is streamed to multiple decoders.

Stopping an Analog Audio Source Stream

You may need to stop one or all the video streams coming from a source.

To stop a video source stream:

1. In the Menu tabs, select Monitor & Control. The Video page appears.
2. Click **HDMI Audio**. The HDMI Audio page appears.
3. Click and drag an HDMI audio source button (or the All button) to the Stop button in the transmitter area. Streaming from that source stops.

Source/s streaming has stopped.

Stopping an HDMI Audio Display Stream



If the selected audio source for an analog output has been set to “HDMI Audio (Stereo Downmix)” the audio output can only be stopped from the HDMI Audio page..

To stop an HDMI audio stream on a display:

1. In the Menu tabs, select Monitor & Control. The Video page appears.
2. Click **HDMI Audio**. The HDMI Audio page appears.
3. Click and drag the display or the All button to the Stop button.
4. Release the mouse. Streaming to that display stops.

Display streaming has stopped.

Pairing USB Hosts and Devices

Use drag-and Drop control to pair USB hosts (such as a PC, laptop etc.) and USB devices (such as a keyboard, mouse, webcam, etc.) connected to USB ports on detected encoders and decoders.



If “Simultaneous Mode” is enabled on the USB host port, it can be paired with up to 7 device endpoints.

If “Simultaneous Mode” is disabled, a USB host port can only be paired with a single USB device endpoint.

The USB page includes two main areas. The:

- **USB Host** area, which includes drag-and-drop buttons for all the encoder USB Hosts that are detected by the system, and a stop button to stop communication from a host.
- **USB Device** area, which includes drag-and-drop buttons for all the decoder USB device endpoints and a Stop button to stop communication from a device.

The USB page enables performing the following actions:

- [Pairing a Host to a Device](#) on page [25](#).
- [Stopping Communication from a USB Host](#) on page [25](#).
- [Stopping Communication from a USB device](#) on page [26](#).

Pairing a Host to a Device

To pair a USB host with a USB device:

1. In the Menu tabs, select Monitor & Control. The Video page appears.
2. Click **USB**. The USB page appears.



Figure 16: Monitor & Control Tab – USB Page

3. Click and drag a USB host button from the Host side to a USB device on the Device side.
4. Release the mouse. The active USB host name appears below the group name. The selected host and routed devices change their color.

USB hosts and devices are paired.

Stopping Communication from a USB Host

To stop communication from a USB host:

1. In the Menu tabs, select Monitor & Control. The Video page appears.
2. Click **USB**. The USB page appears.
3. Click and drag a USB host button to the Stop button in the Host area. Communication from USB host has stopped.

Stopping Communication from a USB device

To stop communication from a USB device:

1. In the Menu tabs, select Monitor & Control. The Video page appears.
2. Click **USB**. The USB page appears.
3. Click and drag a USB device to the Stop button in the Device area.
Communication from USB device has stopped.

Routing IR Signals

Route IR inputs and outputs on detected encoders and decoders via drag-and-Drop control.

The IR page includes two main areas. The:

- **IR Input** area, which includes drag-and-drop buttons for all the encoder IR input ports that are detected by the system, and a stop button to stop IR streaming to the encoders.
- **IR Output** area, which includes drag-and-drop buttons for all the decoder IR output ports.

Use IR page to perform the following actions:

- [Streaming Global Broadcast IR Inputs](#) on page [26](#).
- [Connecting IR Out to IR Input](#) on page [27](#).
- [Stopping IR Broadcast Streaming](#) on page [27](#).

Streaming Global Broadcast IR Inputs

To broadcast an IR input to all available IR outputs:

1. In the Menu tabs, select Monitor & Control. The Video page appears.
2. Click **IR**. The IR page appears.

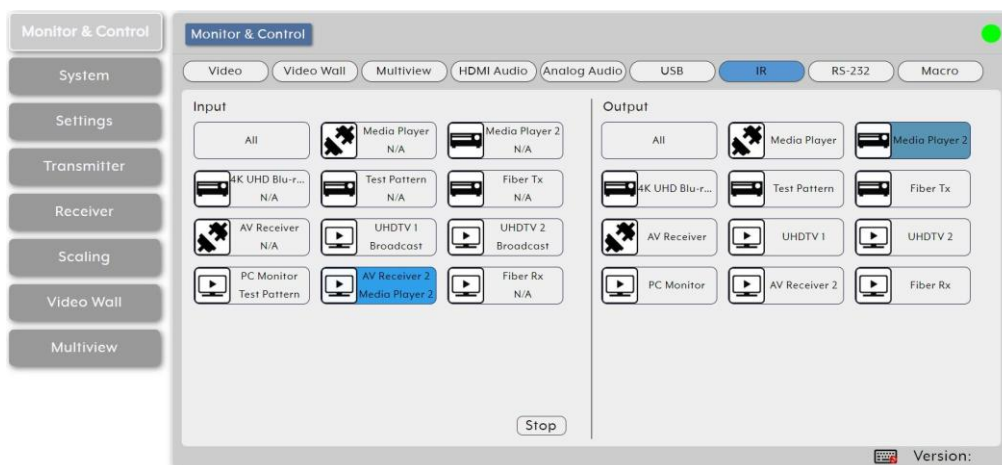

Figure 17: Monitor & Control Tab – IR Page

3. Click and drag an IR input button from the Input side to All on the Output side.

4. Release the mouse. The word broadcast appears in the appropriate IR input button. The selected input and output devices change their color.

IR Input is routed to all available IR outputs.

Connecting IR Out to IR Input

To connect an IR Output to an IR input:

1. In the Menu tabs, select Monitor & Control. The Video page appears.
2. Click **IR**. The IR page appears.
3. Click and drag an IR output button from the Output side to an input IR on the Input side.
4. Release the mouse. The IR output name appears in the IR input button. The selected input and output devices change their color.



IR inputs may also be dragged and dropped onto IR outputs to activate a new route.

IR outputs is routed to IR Input.

Stopping IR Broadcast Streaming

To stop IR input signal broadcast:

1. In the Menu tabs, select Monitor & Control. The Video page appears.
2. Click **IR**. The IR page appears.
3. Click and drag an IR Input button or the All button to the Stop button in the Input area.

IR streaming has stopped.

Routing RS-232 Signals

Route RS-232 signals, via drag and drop, from RS-232 ports on detected encoders to RS-232 ports on detected decoders.

The RS-232 port on a standard extension unit contains one sender (Rx pin) and one receiver (Tx pin).



You can send one or multiple RS-232 signals from different encoders to a single RS-232 port on a decoder.

Use the Global Broadcast option If you need to send an RS-232 signal to more than one decoder.

The RS-232 page includes two main areas. the:

- **Sender** area, which includes drag-and-drop buttons for all the encoder RS-232 ports that are detected by the system, and a stop button to stop RS-232 streaming to the encoders.
- **Receiver** area, which includes drag-and-drop buttons for all the decoder RS-232 output ports.

Use RS-232 page to perform the following actions:

- [Streaming Global Broadcast RS-232 Inputs](#) on page 28.
- [Routing RS-232 Output to RS-232 Input](#) on page 28.
- [Stopping RS-232 Broadcast Streaming](#) on page 29.

Streaming Global Broadcast RS-232 Inputs

To broadcast an RS-232 input to all available RS-232 outputs:

1. In the Menu tabs, select Monitor & Control. The Video page appears.
2. Click **RS-232**. The RS-232 page appears.

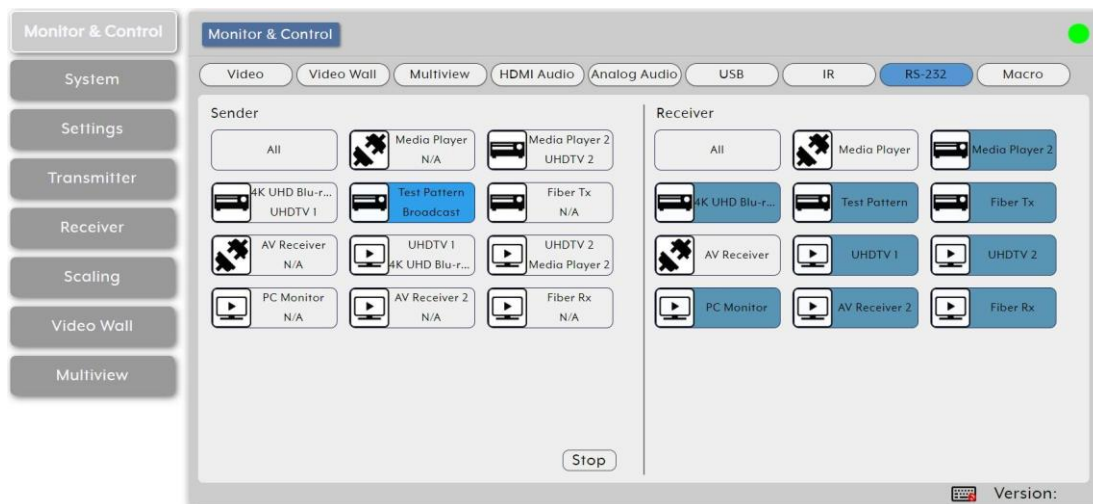

Figure 18: Monitor & Control Tab – RS-232 Page

3. Click and drag an RS-232 input button from the Sender side to All on the Receiver side.
4. Release the mouse. The word broadcast appears in the appropriate RS-232 input button.

The selected input and output devices change their color.

RS-232 Input is routed to all available RS-232 outputs.

Routing RS-232 Output to RS-232 Input

To route an RS-232 signal on the Receiver side to an RS-232 input on the sender side:

1. In the Menu tabs, select Monitor & Control. The Video page appears.
2. Click **RS-232**. The RS-232 page appears.
3. Click and drag an RS-232 output button from the Receiver side to an RS-232 input on the Sender side.
4. Release the mouse. The RS-232 output name appears in the RS-232 input button.
The selected input and output devices change their color.



RS-232 inputs on the sender side can also be dragged and dropped onto RS-232 outputs to activate a new route.

RS-232 output is routed to RS-232 Input.

Stopping RS-232 Broadcast Streaming

To stop RS-232 input signal broadcast:

1. In the Menu tabs, select Monitor & Control. The Video page appears.
2. Click **RS-232**. The RS-232 page appears.
3. Click and drag an RS-232 Input button or the All button to the Stop button in the Input area.

IR streaming has stopped.

Activating a Macro

You can activate macros that have been pre-defined and stored within the **KDS-8-MNGR** using the following simple interface. To define Macros, see [Creating Macros](#) on page [35](#)).



Only one macro can be executed at a time.

Activating a Predefined Macro

To activate a Macro:

1. In the Menu tabs, select Monitor & Control. The Video page appears.
2. Click **Macro**. The RS-232 page appears.

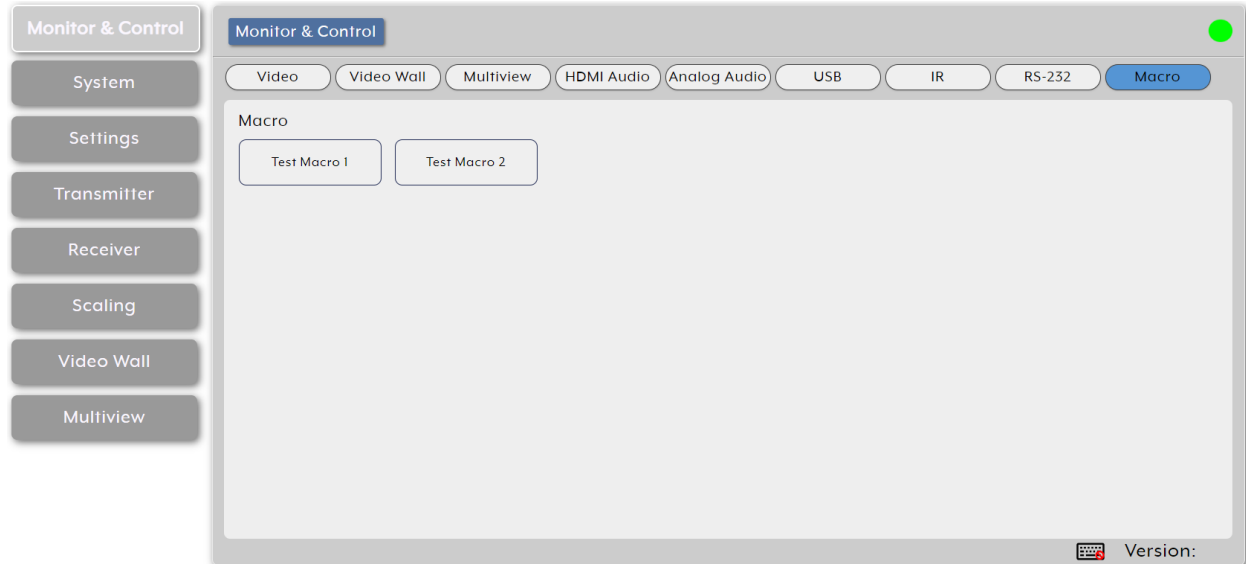

Figure 19: Monitor & Control Tab – Macro Page

3. Click a Macro.
the selected Macro button remains blue until execution completion of the selected Macro.

Macro is activated.

Configuring the System

Set KDS-8-MNGR IP configuration for both LAN ports, interface language, login and user management, and firmware update functionality.

KDS-8-MNGR System Tab enables performing the following actions:

- [Setting IP Definitions for LAN1 and LAN2](#) on page [30](#).
- [Running System Basic Commands](#) on page [31](#).
- [Resetting the System](#) on page [31](#).
- [Upgrading the Firmware](#) on page [32](#).



When not logged in, only the “Monitor & Control” and “System” tabs are available.

Setting IP Definitions for LAN1 and LAN2

Set the IP Mode address, netmask, and gateway Network definitions for each LAN port (DHCP or Static IP).

When a LAN port is set to DHCP mode, it automatically attempts to obtain proper configuration information from the local DHCP server. If no DHCP server is available, it will automatically assign itself an APIPA address from the 169.254.xxx.xxx range.

To configure the Network settings manually:

1. In the Menu tabs, select System. The System page appears.

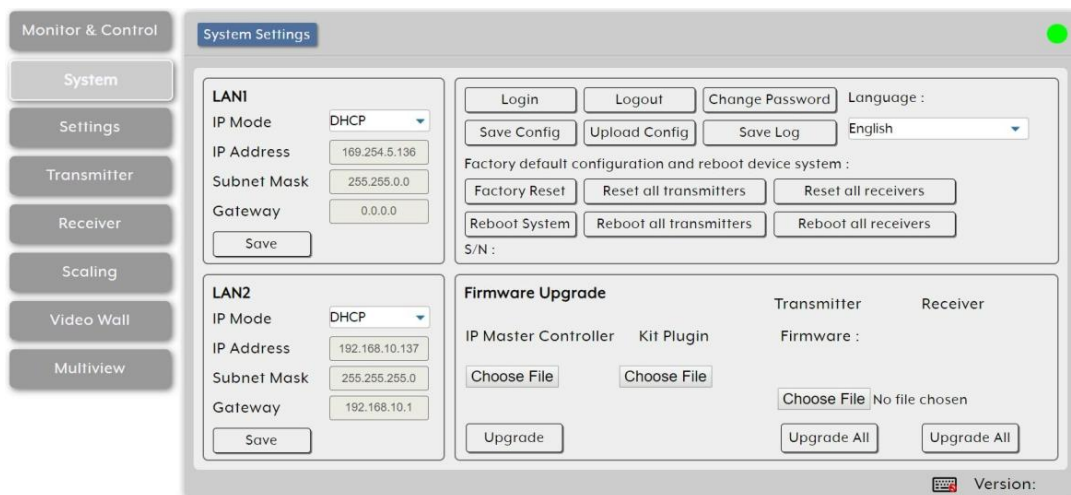

Figure 20: System page

2. Set IP mode to Static.
3. Manually enter IP Address, Subnet Mask and Gateway.
4. Click **Save**.



By default, both LAN ports are set to DHCP mode. The current IP address can be verified using the HDMI output or RS-232 if the Device Discovery software is not available.

Running System Basic Commands

Use predefined system commands to carry out system basic actions.

To run system commands:

1. In the Menu tabs, select System. The System page appears.
2. In the top right area of the system page, click:
 - **Login** to log into the embedded web pages.
 - **Logout** to exit the embedded web pages.
 - **Change Password** to change the admin login password.
 - **Save Config** to save the current system configuration as a *.bin file to your local PC.
 - **Upload Config** to upload a saved system configuration file. Click **Upload Config** to locate the saved *.bin file, then click the “Open” button.
 - **Save Log** to generate and save a copy of the current log data in, *.zip format, to your local PC (this system log file can help diagnose configuration issues or other problems).



The generated file is password protected and is only intended for use by authorized technical support.

3. If required, open the drop-down list to select the user language for the embedded web pages.

Basic commands are carried out.

Resetting the System

KDS-8-MNGR provides several reset options.

To reset the system:

1. In the Menu tabs, select System. The System page appears.
2. In the top right area of the system page, click:
 - **Factory Reset** to reset the unit back to its factory default settings.



Factory Reset does NOT clear the transmitter and receiver history tables. To completely remove old transmitter and receiver units from the system, use the “Remove” option on the Transmitter and Receiver tabs (see [Configuring Transmitters](#) on page 45 and [Configuring Receivers](#) on page 47).

- **Reset all transmitters** to reset all detected transmitters back to their factory default settings.
- **Reset all receivers** to reset all detected receivers back to their factory default settings.
- **Reboot System** to reboot this KDS-8-MNGR unit.

- **Reboot all transmitters** to reboot all detected transmitters.
 - **Reboot all receivers** to reboot all detected receivers.
3. View the **KDS-8-MNGR S/N** (Serial Number).

System reset/reboot is complete.

Upgrading the Firmware

Use **KDS-8-MNGR** to remotely update the firmware of this unit and the detected transmitters and receivers in the system. the Kit Plugin option is currently not available.



The update process can take several minutes to complete, especially if there are multiple transmitters and receivers in the system.

Do not power off any units during the update process.

KDS-8-MNGR enables performing the following firmware upgrades:

- [Upgrading KDS-8-MNGR Firmware](#) on page [32](#).
- [Upgrading Transmitter/Receiver Firmware](#) on page [33](#).

Upgrading KDS-8-MNGR Firmware

To upgrade the **KDS-8-MNGR** firmware:

1. In the Menu tabs, select System. The System page appears.

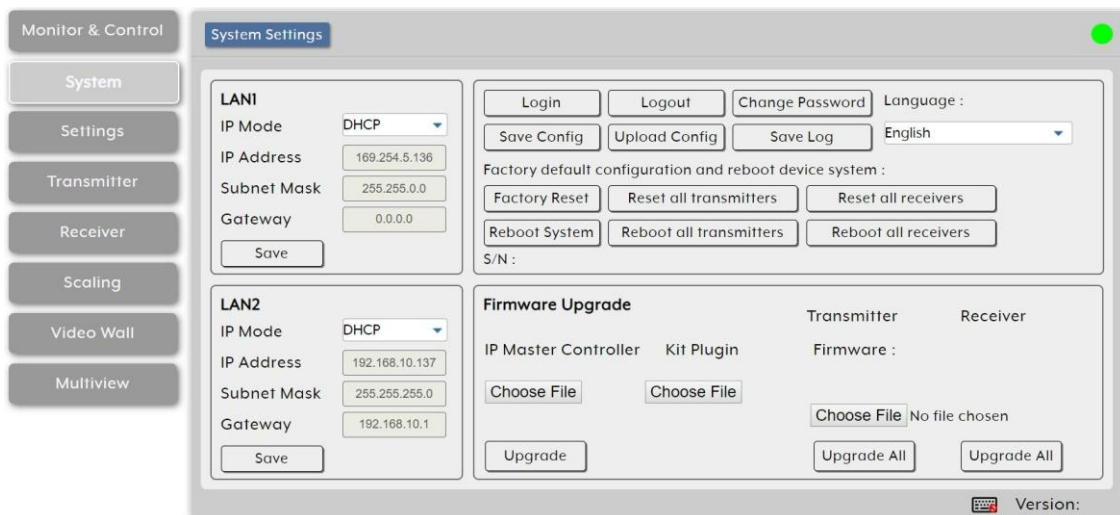

Figure 21: System Page

2. Under IP Master Controller (**KDS-8-MNGR**), click **Choose file**. The file selection window opens.
3. Select the firmware update file (*.bin format) located on your local PC.
4. Click **Upgrade** to begin the firmware update process. Once the firmware update process has completed the unit reboots.

Firmware upgrade is complete.

Upgrading Transmitter/Receiver Firmware

You can upgrade the firmware of all the detected transmitters/receivers at once.

To upgrade the transmitter/receiver firmware:

1. In the Menu tabs, select System. The System page appears.
2. Under transmitter, click **Choose file**. The file selection window opens.
3. Select the transmitter/receiver firmware update file (*.apz format) located on your local PC.
4. Click **Upgrade All** (under transmitters or under receivers, depending on the chosen file) to begin the firmware update process. Once the firmware update process has completed the transmitters/receivers reboot.

Firmware upgrade is complete.



The transmitter/receiver firmware is stored within the **KDS-8-MNGR** after upload and is also used when performing individual unit updates via the Transmitter and Receiver tabs.

Configuring System Settings

KDS-8-MNGR enables configuration of different internal systems and interfaces, including group and macro creation, manual IR and RS-232 command broadcasting, I/O trigger assignment, EDID management, and setting the system's clock and event scheduling.

KDS-8-MNGR enables performing the following actions:

- [Creating Groups](#) on page [33](#).
- [Creating Macros](#) on page [35](#).
- [Sending RS-232/IR commands](#) on page [36](#).
- [Assigning I/O Triggers](#) on page [37](#).
- [Managing EDID](#) on page [38](#).
- [Setting the Time](#) on page [39](#).
- [Managing Scheduling](#) on page [40](#).

Creating Groups

Groups are listed Under Device Group Name in the Group page. You can include multiple receiving endpoints in one group for simple, single click targets, for routing AV, USB or IR/RS-232 sources. Once created, each group appears within the appropriate section of the Monitor & Control Tab (see [Monitoring and Controlling Decoders and Encoders](#) on page [14](#)) beside standard receivers.

To create a group:

1. In the Menu tabs, select **Settings**. The Group page appears.

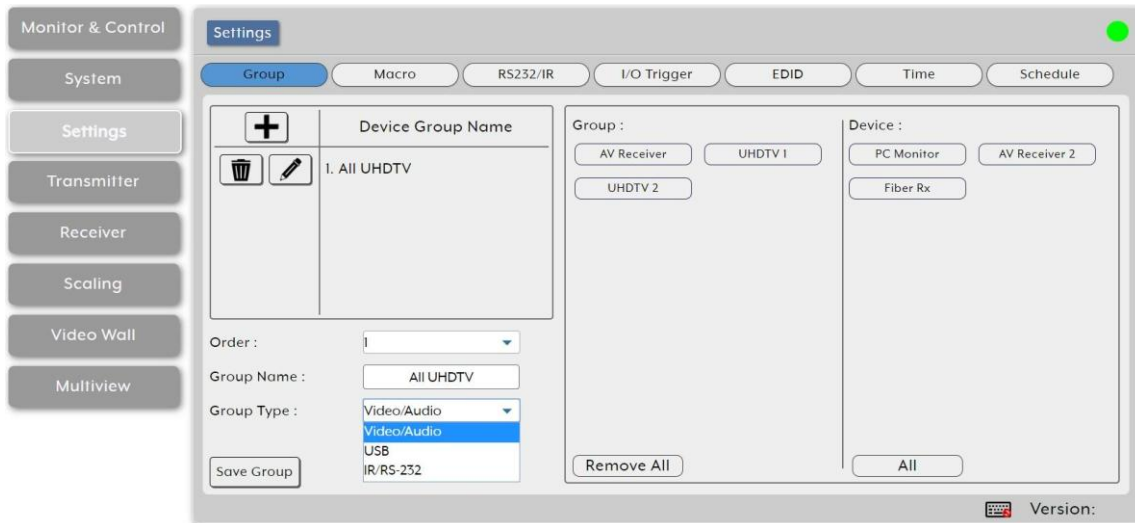



Figure 22: Settings Tab – Group Page

2. Click **+** to create a new group.



Click  to edit an existing group.

Click  to delete a group

3. Enter group details:

- Next to Order, open the drop-down box to select the group order (also use to change the order of existing groups).



Groups are displayed in the Monitor & Control tab in the same order.

- Enter Group Name.
- Select Group Type from the drop-down list. Group type determines the signal type for this group: Video/Audio, USB, and IR/RS-232. This selection affects the type of receiver endpoints available within the Device List.
- In the Device area, which lists all the available decoder acceptors (displays), click an acceptor to move it to the Group area, which lists all the acceptors in the selected group. Click **All** to move all the devices to the group.
- In the Group area, which lists the devices in the group, click a device button to remove it from the group (back to the Device area) or click **Remove All** to remove all of them.

4. Click **Save Group**.

A group is saved to the list.

Creating Macros

KDS-8-MNGR can create operational command sequences that can be activated via **Kramer Control**, external triggers, or from within the embedded web pages. Macros are a flexible and powerful tool. They can be as simple as selecting a new input for a decoder or a complex sequence of source, resolution, mode, and audio changes executed in sequence. Up to 16 macros can be defined, each containing up to 64 commands.

To create a Macro:

1. In the Menu tabs, select **Settings**. The Group page appears.
2. Click **Macro**. The Macro page appears.

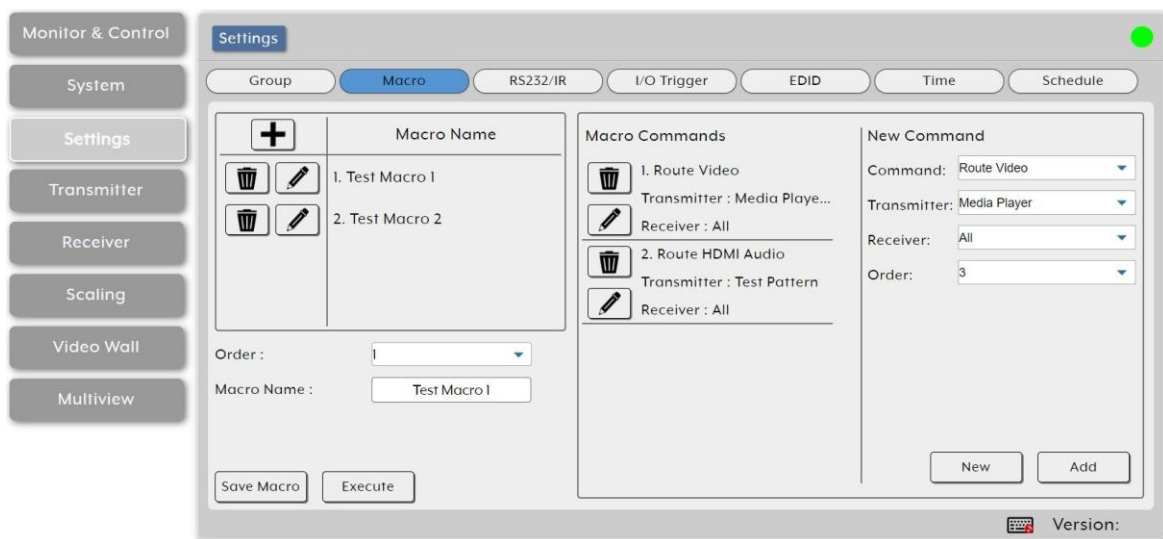







Figure 23: Settings Tab – Macro Page

3. Click **+** to create a new macro.
 -  Click  to edit an existing macro.
 -  Click  to delete a macro.
4. Next to Order, open the drop-down box to select the macro order (also use to change the order of existing macros).
 -  Macros are displayed in the Monitor & Control tab in the same order and when assigning IR/trigger functionality.
5. Enter Macro Name.
6. Under New Command:
 - a. Click **New**.
 - b. Select the command type from the drop-down list.
 - c. Select the other parameters relevant for this command type (Transmitter and Receiver for this command).
 - d. Set the command order in the macro sequence.

- e. Click **Add**. The command is added to the Macro Commands sequence.
 7. Click **Save Macro**.
 8. If required, click **Execute** to test the Macro.
- A Macro is saved to the Macro Name list.

Sending RS-232/IR commands

You can manually send single RS-232 or IR commands to specific decoder endpoints within the system.

To send single RS-232 or IR commands:

1. In the Menu tabs, select **Settings**. The Group page appears.
2. Click **RS232/IR**. The RS232/IR page appears.

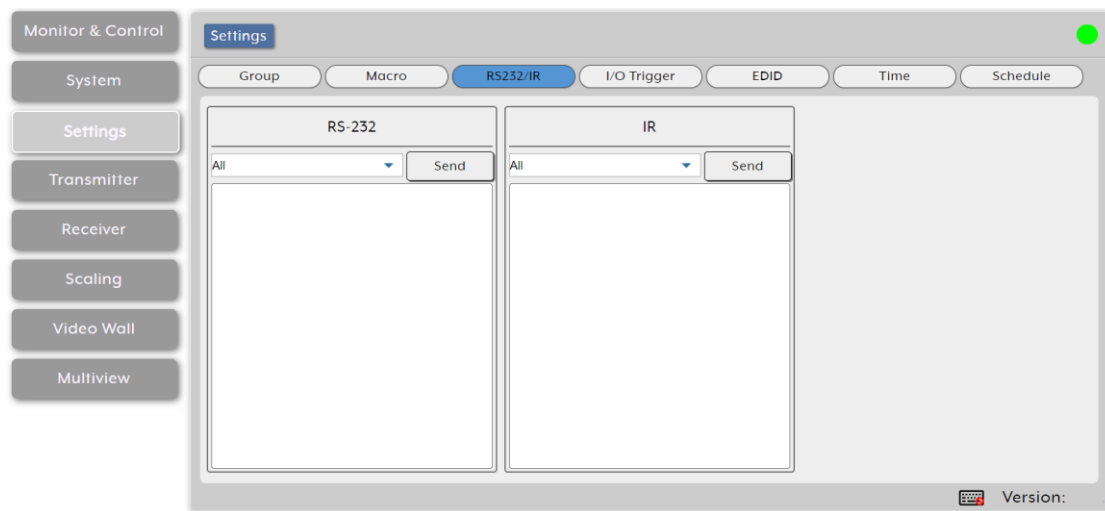



Figure 24: Settings Tab – RS232/IR Page

3. For RS-232:
 - a. Select the command target from the drop-down box.
 - b. Enter or copy the command to the empty area below RS-232.

 To transmit hex data, each ASCII hex pair (octet) must be preceded by “\x”. For example, a carriage return would be “\x0D”.
 - c. Click **Send** to send the command immediately.
4. For IR:
 - a. Select the command target from the drop-down box.
 - b. Enter or copy the command to the empty area below IR.
 - c. Click **Send** to send the command immediately.

RS-232/IR command is sent.

Assigning I/O Triggers

You can assign macros (see [Creating Macros](#) on page 35) to each of the 8 trigger inputs on the unit as well as to the 8 IR remote buttons.

To assign a macro to a trigger:

- 1. In the Menu tabs, select **Settings**. The Group page appears.
- 2. Click **I/O Trigger**. The I/O Trigger page appears.

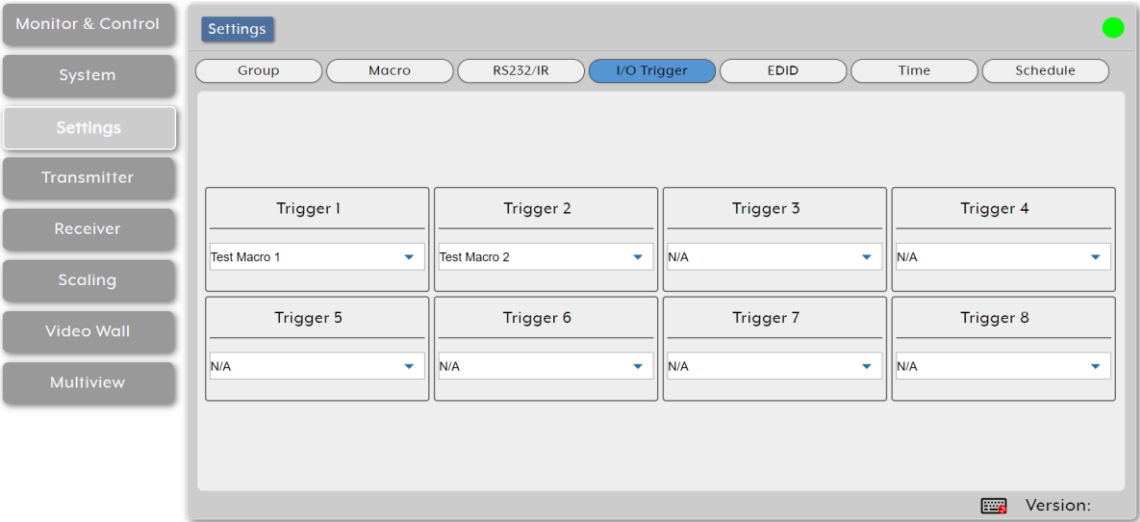

Figure 25: Settings Tab – I/O Trigger Page

- 3. Select the Macro from the drop-down list under a trigger.
A macro is assigned to a Trigger.

Managing EDID

Manage and assign EDID to any or all the available encoders. You can assign an EDID from the 6 default EDIDs, the displays connected to any encoder, or from a user uploaded EDID.

To Assign an EDID to an input on the encoder:

1. In the Menu tabs, select **Settings**. The Group page appears.
2. Click **EDID**. The EDID page appears.

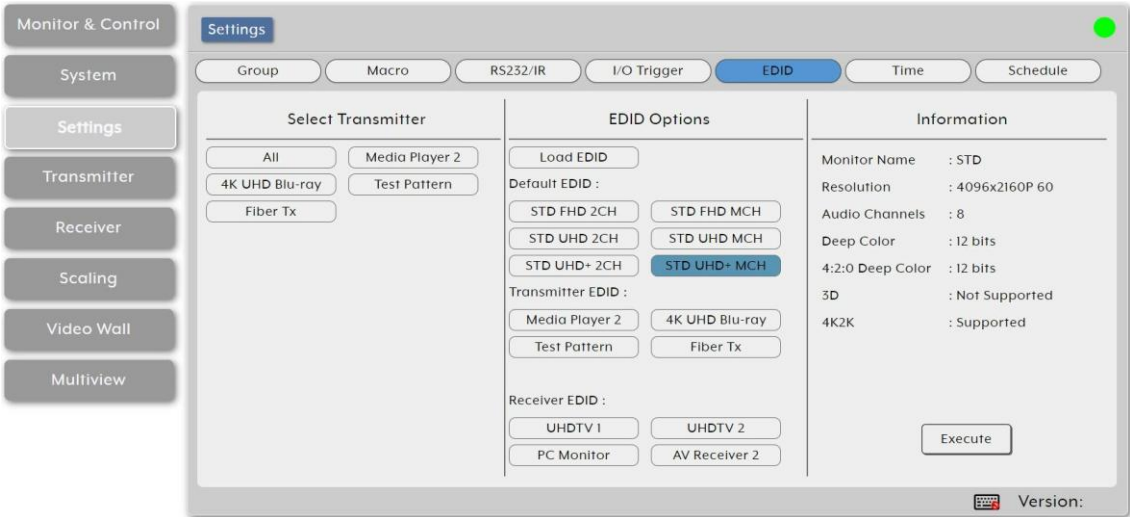



Figure 26: Settings Tab – EDID Page

3. Under Select Transmitter (that lists all the available encoders and an All button), click one or more transmitter button (or click **All**) for receiving EDID.
4. Under EDID Options, select an available EDID source:
 - Click **Load EDID** and select a custom EDID file (*.bin format) from a selection window on your PC.

 In some cases, a custom or external EDID may cause compatibility issues with certain sources. If this happens, we recommend that you switch to one of the 6 default EDIDs for maximum compatibility.

- Click 1 of the following 6 default EDIDs:

Default EDIDs	
STD FHD 2CH	1920x1080p@60Hz (4.95Gbps) & 8-bit color, LPCM 2.0
STD FHD MCH	1920x1080p@60Hz (4.95Gbps) & 8-bit color, LPCM 7.1 & Bitstream
STD UHD 2CH	3840x2160p@30Hz (10.2Gbps) & Deep Color (8/10/12-bit), LPCM 2.0
STD UHD MCH	3840x2160p@30Hz (10.2Gbps) & Deep Color (8/10/12-bit), LPCM 7.1 & Bitstream
STD UHD+ 2CH	3840x2160p@60Hz (18Gbps) & Deep Color (8/10/12-bit), LPCM 2.0
STD UHD+ MCH	3840x2160p@60Hz (18Gbps) & Deep Color (8/10/12-bit), LPCM 7.1 & Bitstream

- Under Transmitter EDID, click an Encoder source from which to select the EDID.
- Under Receiver EDID, click a decoder display from which to select the EDID.

 In most cases, assigning a new EDID to an input will cause the affected input to briefly blink out while EDID is acquired.

5. View EDID information.
6. Click **Execute**.

The EDID displayed in the Information window is sent to all currently selected transmitters.

Setting the Time

Automatically set and sync the **KDS-8-MNGR** system clock using a standard internet NTP (Network Time Protocol) server.

To Assign an EDID to an input on the encoder:

1. In the Menu tabs, select **Settings**. The Group page appears.
2. Click **Time**. The Time page appears.

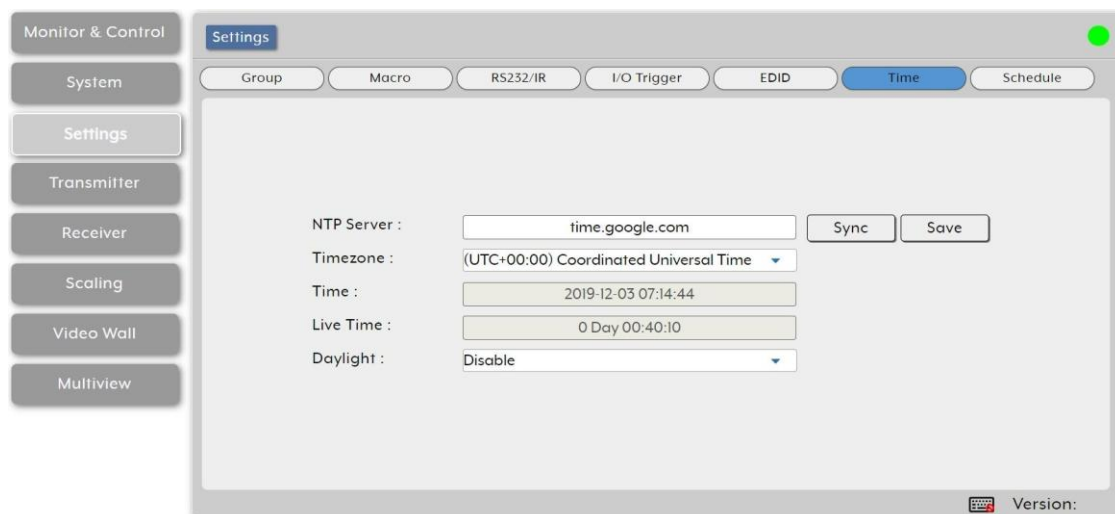



Figure 27: Settings Tab – Time Page

3. Next to NTP Server, Enter the hostname or IP address of the preferred NTP server to use for time synchronization.
4. Click **Save** to store the new information.
5. Click **Sync** to force the unit to sync to the NTP server.

 **KDS-8-MNGR's** clock does not have a battery backup, so time is not kept once the unit is unplugged. However, the time will automatically sync at power up if an internet connection is available and the NTP server is valid.

6. Next to Timezone, select your local time zone from the drop-down list.
7. Next to Time, view the current time on the device.
8. Next to Live Time, view the device online time since its last reboot.

9. Next to Daylight, enable or disable support for daylight savings time.

Time definitions are set.

Managing Scheduling

KDS-8-MNGR enables scheduling the execution of macros. A macro can be scheduled to execute once at a specific time and date, can be repeated periodically, or recur at set times on specific days of the week.

Scheduling can be set in the following ways:

- [Executing a Macro Once](#) by date on page [40](#).
- [Executing a Macro Multiple](#) Times on page [42](#).
- [Defining a Weekly Schedule](#) on page [44](#).

Executing a Macro Once by date

You can execute a selected macro once at a specific date and time.

To define a one-time schedule by date:

1. In the Menu tabs, select **Settings**. The Group page appears.
2. Click **Schedule**. The Schedule page appears.

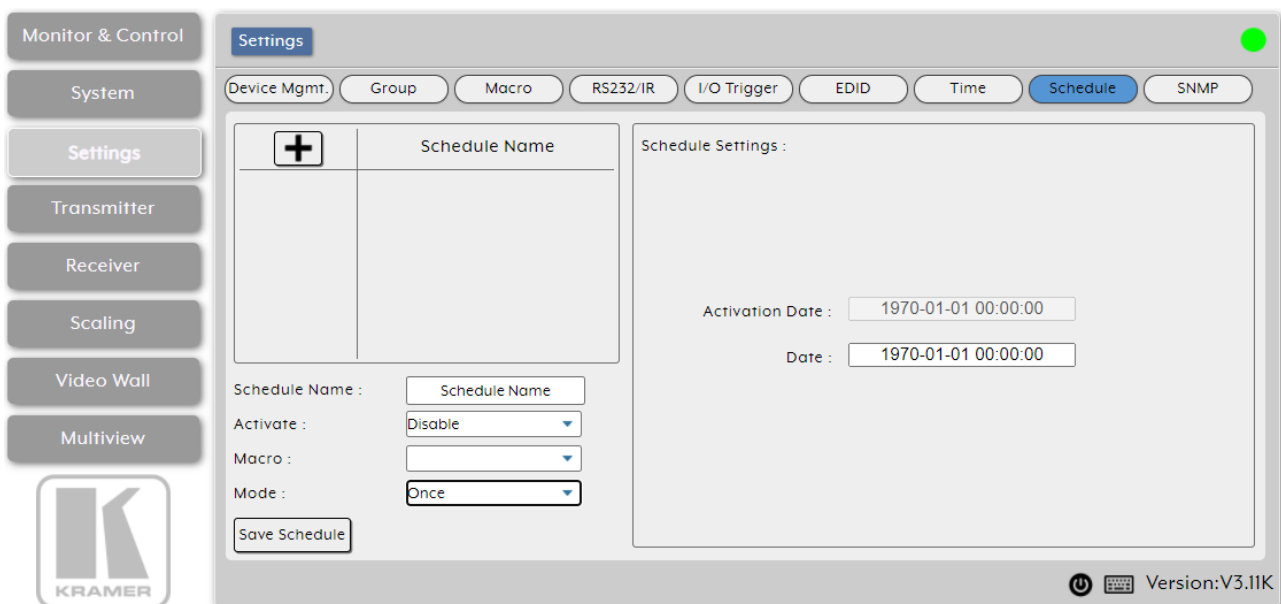



Figure 28: Settings Tab – Schedule Page

3. Click **+** to create a new schedule.

- Click  to edit an existing schedule.
- Click  to delete a schedule

4. Enter Schedule Name.

5. Next to Activate, Enable or Disable the current schedule event.

- 6. Next to Macro, select the macro (from the drop-down list) to activate at the scheduled time.
- 7. Next to Mode, select **Once**. The Once Scheduling setting appears.

Activation Date : 1970-01-01 00:00:00

Date : 1969-12-31 22:00:00

Figure 29: Scheduling – Once Mode

- 8. Click Date text box for a one-time macro execution. A calendar window opens:

December 1969

Su	Mo	Tu	We	Th	Fr	Sa
	1	2	3	4	5	6
7	8	9	10	11	12	13
14	15	16	17	18	19	20
21	22	23	24	25	26	27
28	29	30	31			

Time 22:00:00

Hour

Minute

Second

Now Done

1969-12-31 22:00:00

Figure 30: Activate Date – Calendar Window

- 9. Click **Now** to change the date and time to the present.

July 2021

Su	Mo	Tu	We	Th	Fr	Sa
				1	2	3
4	5	6	7	8	9	10
11	12	13	14	15	16	17
18	19	20	21	22	23	24
25	26	27	28	29	30	31

Time 14:06:50

Hour

Minute

Second

Now Done



Figure 31: Setting Present Date and Time

- 10. Select the execution date.
 - 11. Use the sliders to set the execution time.
 - 12. Click **Done**.
 - 13. Click **Save Schedule**.
- Schedule is set by date to execute a macro once.

Executing a Macro Multiple Times

You can execute a selected macro for a predefined number of times.

To define a schedule by time:

- 1. In the Menu tabs, select **Settings**. The Group page appears.
- 2. Click **Schedule**. The Schedule page appears.
- 3. Click **+** to create a new schedule.
- Click  to edit an existing schedule.
 - Click  to delete a schedule
- 4. Enter Schedule Name.
- 5. Next to Activate, enable or disable the current schedule event.
- 6. Next to Macro, select the macro (from the drop-down list) to activate at the scheduled time.
- 7. Next to Mode, select **Repeat**.

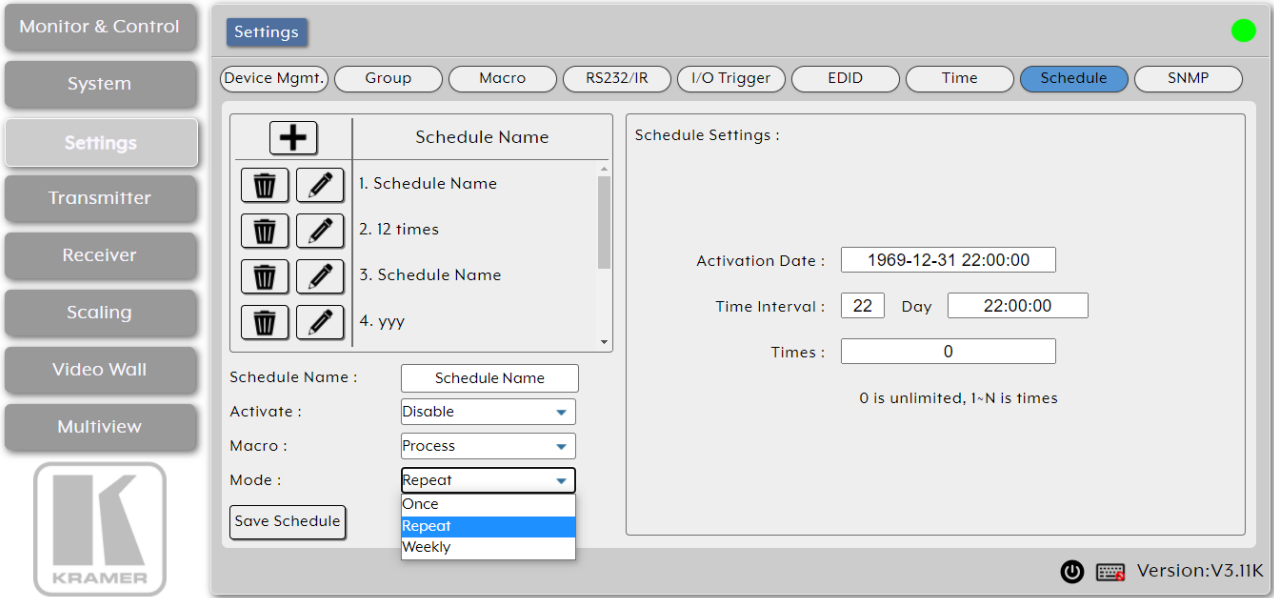

Figure 32: Settings Tab – Schedule Page

8. Click Activate Date box for a one-time macro execution. A calendar window opens:

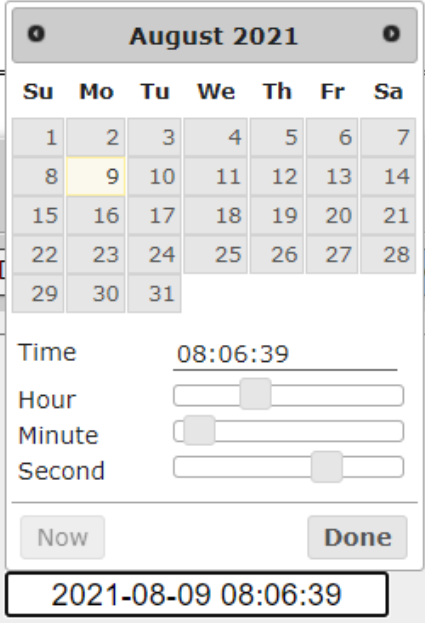

Figure 33: Activate Date – Calendar Window

- Select the execution date.
 - Use the sliders to set the execution time or click **Now** to set to the current time.
 - Click **Done**.
9. Enter Time Interval text box to set the number of days this schedule is repeated.
10. Click Day text box to set the execution time per day
11. Click Times box to set the number of times this macro will be executed from the set date and on. Select 0 to have this schedule run repeatedly.

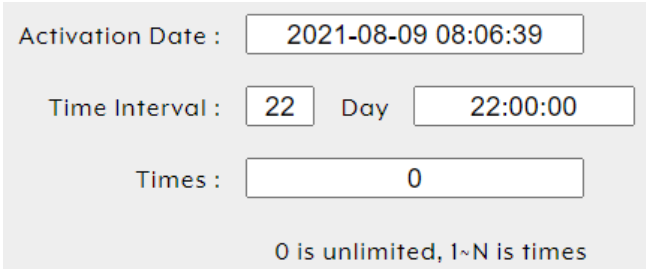

Figure 34: Date – Repeat Scheduling Window

12. Click **Save Schedule**.
- Schedule is set to repeat a set number of times.

Defining a Weekly Schedule

You can execute a selected macro on a weekly schedule.

To define a weekly schedule:



1. In the Menu tabs, select **Settings**. The Group page appears.
2. Click **Schedule**. The Schedule page appears.
3. Click **+** to create a new schedule.
 Click  to edit an existing schedule.
 Click  to delete a schedule
4. Enter Schedule Name.
5. Next to Activate, enable or disable the current schedule event.
6. Next to Macro, select the macro (from the drop-down list) to activate at the scheduled time.
7. Next to Mode, select **Weekly**. The Week Scheduling setting appears.

Figure 35: Scheduling – Date Mode



8. Click Activate Date box. A calendar window opens:

Figure 36: Activate Date – Calendar Window

9. Select the execution date.
 10. Use the sliders to set the execution time or click **Now** to set to the current time.
 11. Click **Done**.
 12. Check the scheduling week days or check **All** for each day.
 13. Set the macro execution time for the selected days.
 14. Click **Save Schedule**.
- Schedule is set by week.

Configuring Transmitters

KDS-8-MNGR enables viewing and configuring detected encoder details.

-  Previously detected encoders that are not currently detected, are identified by a disconnected icon () and cannot be used for routing.

Transmitter tab enables performing the following actions:

- [Viewing and Configuring Encoder Settings](#) on page 45.
- [Removing an Encoder](#) on page 47.

Viewing and Configuring Encoder Settings

To view and configure encoder settings:

1. In the Menu tabs, select **Transmitter**. The Transmitter page appears.

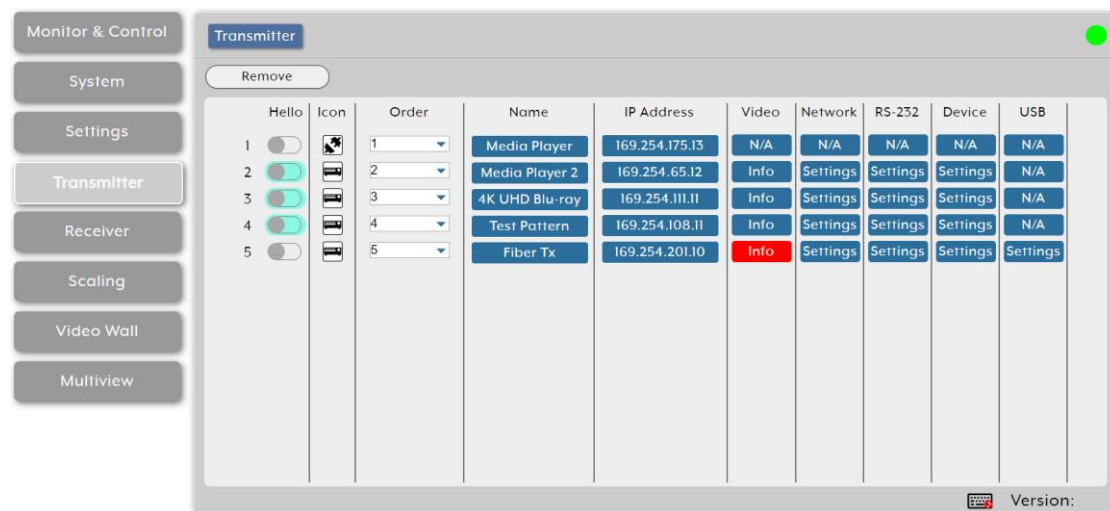





Figure 37: Transmitter Page

2. Perform the following actions:
 - Under Hello, Click a button in the list. The relevant encoder POWER LED flashes to help you identify that encoder in the system. Click again to return to normal operation.

 Note that not all SDVoE devices support the Hello feature. Hello buttons are highlighted for devices that support this feature.

- Under Icon, view the status of the encoder (connected or disconnected).

 If an encoder stream requires more bandwidth than is available, a warning icon () is displayed instead of the normal source icon. The video output from a source displaying this icon may become visually unstable. We recommend that you lower the resolution or the framerate of the stream.

- Under Order, define the order of the encoders in the list via drop-down box. Changing the order here also changes the units' list order in other tabs.
- Under Name, view the name of each source encoder device. Change the device name via Device pop-up window (see below).
- Under IP Address, view the encoder IP address.
- Under Video, Click **Info** to view video source information via the pop-up display window. If no live source is present, Info button appears red.
- Under Network, click **Settings** to view and change Network settings via the Network pop-up window. Click **Save** to accept changes and exit window.
- Under RS-232, click **Settings** to view and change RS-232 settings via the RS-232 pop-up window. Click **Save** to accept changes and exit window.
- Under **Device**, click **Settings** to view and change device settings via the device pop-up window. Select a System Command to the unit (such as factory reset, Reboot the unit, firmware update and transform transceiver to receiver), change the device name, and so on. Click **Save** to accept changes and exit window.

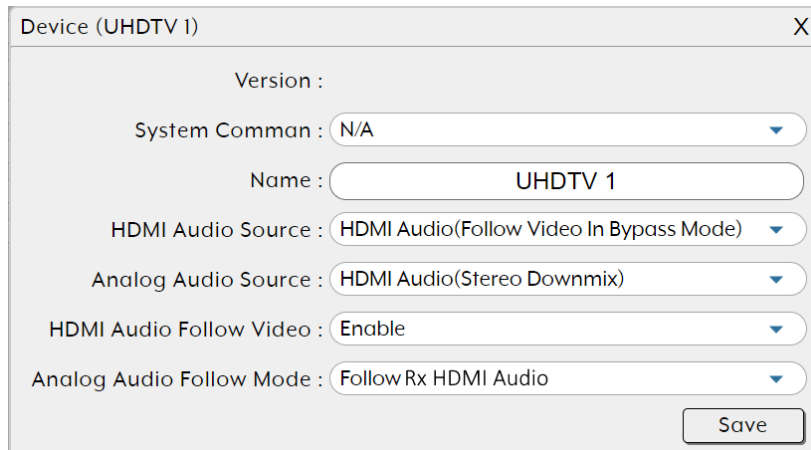



Figure 38: Transmitter Page – Device Settings

- Under USB, click **Settings** to view and change USB settings via the USB pop-up window. Click **Save** to accept changes and exit window.

 USB functionality is not supported by all SDVoE units.

Encoder Settings are configured.

Removing an Encoder

 Only disconnected encoders can be removed.



To remove an encoder from the list:

1. In the Menu tabs, select **Transmitter**. The Transmitter page appears.
2. Click **Remove**. The Remove window appears.
3. Select an encoder from the list.
4. Click **Confirm**.

The selected encoder is removed from the list.

Configuring Receivers

KDS-8-MNGR enables viewing and configuring detected decoder details.

 Previously detected decoders that are not currently detected, are identified by a disconnected icon () and cannot be used for routing.

Receiver tab enables performing the following actions:

- [Viewing and Configuring Decoder Settings](#) on page 47.
- [Removing a Decoder](#) on page 49.

Viewing and Configuring Decoder Settings

To view and configure decoder settings:

1. In the Menu tabs, select **Receiver**. The Receiver page appears.

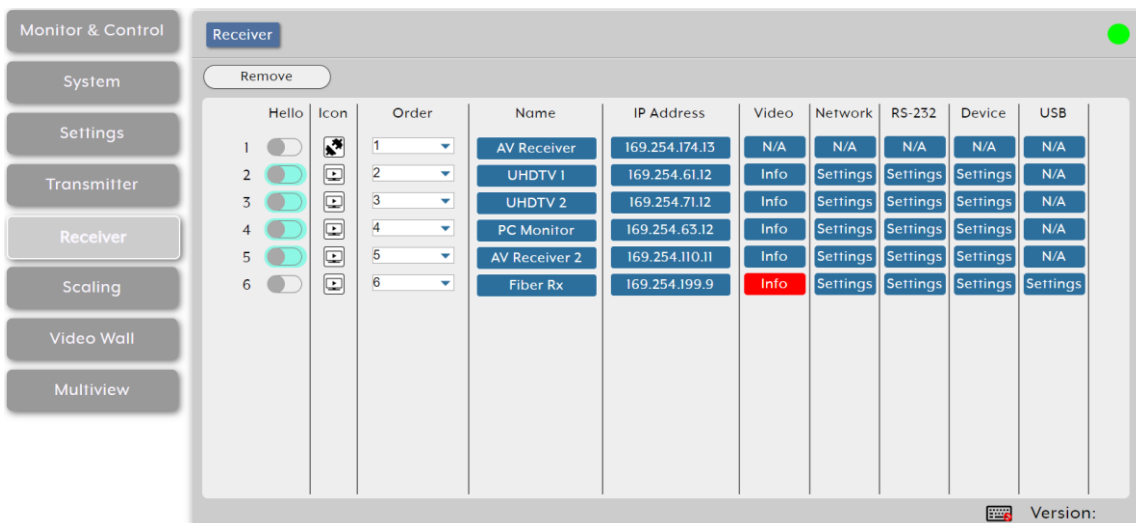

Figure 39: Receiver Page

2. Perform the following actions:

- Under Hello, Click a button in the list. The relevant encoder POWER LED flashes to help you identify that encoder in the system. Click again to return to normal operation.



Note that not all SDVoE devices support the Hello feature. Hello buttons are highlighted for devices that support this feature.

- Under Icon, view the current status of the decoder (connected or disconnected).



If a decoder stream requires more bandwidth than is available, a warning icon (⚠) is displayed instead of the normal source icon. The video output from a source displaying this icon may become visually unstable. We recommend that you lower the resolution or the framerate of the stream.

- Under Order, define the order of the encoders in the list via drop-down box. Changing the order here also changes the units' list order in other tabs.
- Under Name, view the name of each display decoder device. Change the device name via Device pop-up window (see below).
- Under IP Address, view the decoder IP address.
- Under Video, Click **Info** to view video source information via the pop-up display window. If no live source is present, Info button appears red.
- Under Network, click **Settings** to view and change Network settings via the Network pop-up window. Click **Save** to accept changes and exit window.
- Under RS-232, click **Settings** to view and change RS-232 settings via the RS-232 pop-up window. Click **Save** to accept changes and exit window.
- Under **Device**, click **Settings** to view and change device settings via the device pop-up window. Select a System Command to the unit (such as factory reset, Reboot the unit, firmware update and transform transceiver to receiver), change the device name, and so on. Click **Save** to accept changes and exit window.

Device (UHDTV 1) X

Version :

System Command : N/A

Name : UHDTV 1

HDMI Audio Source : HDMI Audio(Follow Video In Bypass Mode)

Analog Audio Source : HDMI Audio(Stereo Downmix)

HDMI Audio Follow Video : Enable

Analog Audio Follow Mode : Follow Rx HDMI Audio

Save

Figure 40: Receiver Page – Device Settings

- Under USB, click **Settings** to view and change USB settings via the USB pop-up window. Click **Save** to accept changes and exit window.



USB functionality is not supported by all SDVoE units.

Decoder Settings are configured.

Removing a Decoder



Only disconnected decoders can be removed.

To remove an encoder from the list:

- In the Menu tabs, select **Receiver**. The Receiver page appears.
- Click **Remove**. The Remove window appears.
- Select a decoder from the list.
- Click **Confirm**.

The selected encoder is removed from the list.

Defining Output Resolution

Set detected decoder output resolution via drag-and-drop control.



Since scaling applies only to the decoder side, a change in the resolution does not affect bandwidth usage.

To define the output resolution:

- In the Menu tabs, select **Scaling**. The Scaling page appears.

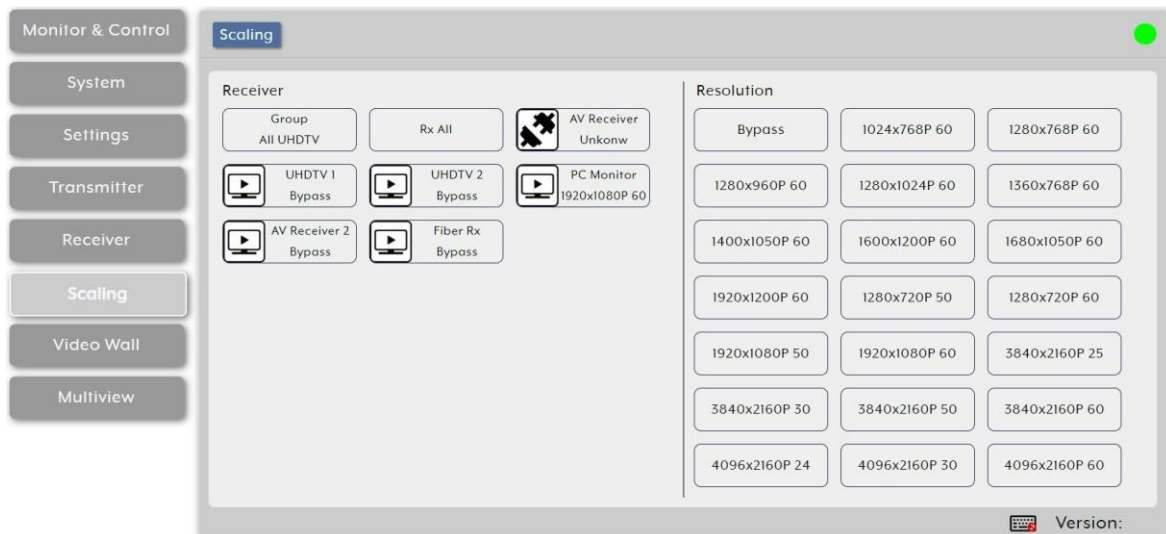

Figure 41: Scaling Page

- Click and drag a decoder/group of decoders/all decoders (Rx All) from the Receiver area to a resolution button in the Resolution area.



Selecting “Bypass” forces that decoder to output all routed sources in their native resolutions.



You can also drag and drop resolutions onto decoders to change their output resolution.

Output resolution is set.

Configuring Video Walls

Configure or modify video walls of up to 8x8 using multiple decoders in a group.

To configure a video wall:

- In the Menu tabs, select **Video Wall**. The Video Wall page appears.

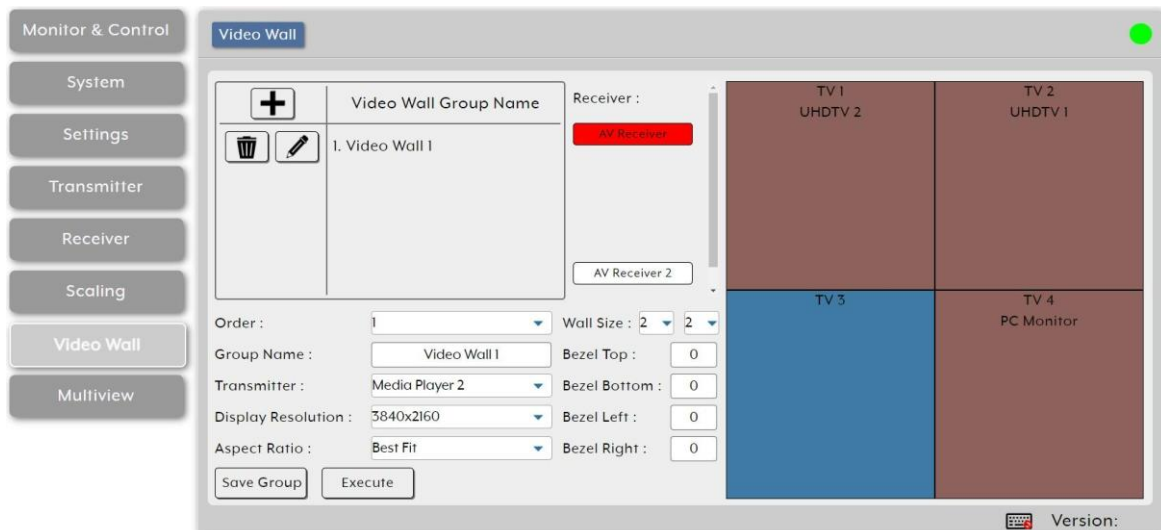

Figure 42: Video Wall Page

- Click **+** to create a new Video Wall group.



Click to edit an existing video wall group.

Click to delete a group

- Enter group details:

- Next to Order, open the drop-down box to select the video wall group order (also use to change the order of existing groups).



Video wall groups are displayed in the Monitor & Control tab in the same order.

- Enter Group Name.
- Select the encoder to use as the video source for the video wall.

- Select the output resolution for all decoders in the video wall to output to their connected displays.
- Select the Aspect Ratio to use when presenting a source across the video wall. Selecting **Best Fit** maintains the aspect ratio of the original source while filling the video wall as much as possible and adding black bars where necessary. Selecting **Full Screen** stretches the source to fit the video wall, regardless of the original source's aspect ratio.
- Select the video wall size rows x columns up to 8x8 (64 devices).
- Set the Bezel Top/Bottom/Left/Right size in pixels.



We recommend that you use the same make and model for all displays within a video wall to avoid bezel and panel size discrepancies.

4. Under Receiver, which lists all the available decoders, drag and drop each decoder to its correct position within the video wall grid to the right of the list. the name of the decoder is displayed within the selected location of the video wall and the display changes colors:
 - Green – the display is assigned to the video wall and is in video wall mode.
 - Red – the display is assigned but is not active/ in the correct mode.
 - Blue – no display has been assigned yet.
5. Click **Save Group** to save the changes to the current video wall configuration.
6. Click **Execute** to save the changes to the current video wall configuration and then execute the changes. If the video wall is not already active, this action activates it.

Video wall is configured.

Configuring Multiviews

Configure or modify the multiviewer functionality for each decoder.



When displaying an encoder source in a multiviewer window, the bandwidth on that encoder should usually be increased, depending on the pixel size of the window on the multiviewer and the frame rate of the input source.

When using 4K sources, we recommend that you enable the “Multiview Divide FPS by two” feature on the encoder.

To configure multiview features:

1. In the Menu tabs, select **Multiview**. The Multiview page appears.

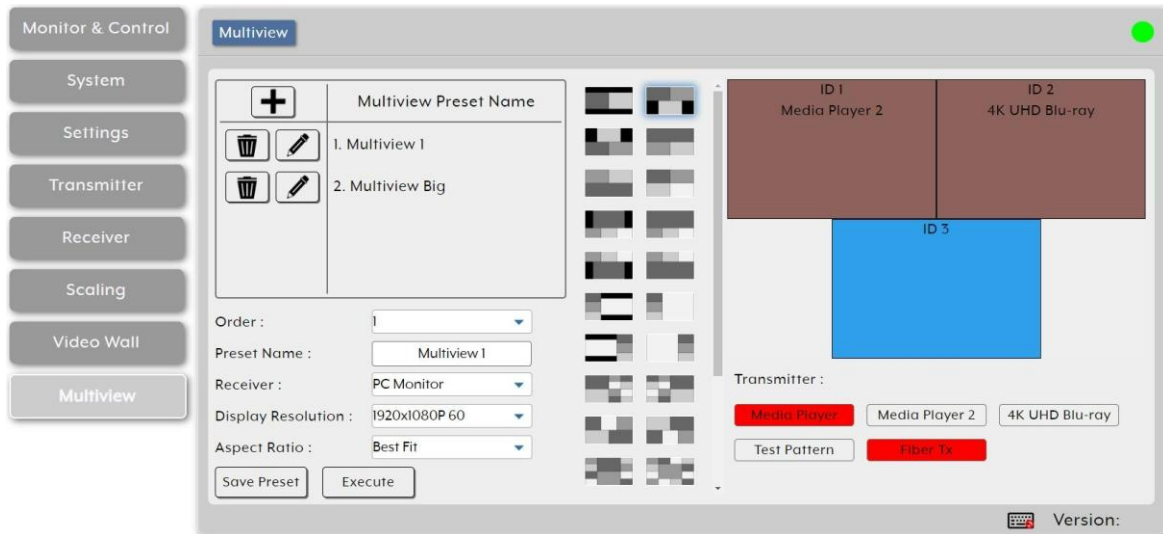

Figure 43: Multiview Page

2. Click **+** to create a new Multiview preset.



Click  to edit an existing Multiview preset.

Click  to delete a preset

Deleting a Multiview preset that is currently active, does not disable the Multiview output. To remove a multiview output, route a new source to that output or disable the output from the Monitor & Control tab (see [Monitoring and Controlling Decoders and Encoders](#) on page 14).

3. Enter Preset details:

- Next to Order, open the drop-down box to select the Multiview preset order (also use to change the order of existing groups).



Multiview presets are displayed in other tabs in the same order.

- Enter Multiview Preset Name.
- Select the decoder display to output Multiview preset.
- Select the resolution for the decoder Multiview output.
- Select the Aspect Ratio to use when presenting the sources in the Multiview windows. Selecting **Best Fit** maintains the aspect ratio of the original source while filling the video wall as much as possible and adding black bars where necessary. Selecting **Full Screen** stretches the source to fit the video wall, regardless of the original source's aspect ratio.



This setting applies to all sources/windows within the current Multiview preset.

- Scroll through the various predefined Multiview layouts to select the required configuration (windows location and number) for the Multiview window.



Customized layouts are not currently supported.

- Set the Bezel Top/Bottom/Left/Right size in pixels.



We recommend that you use the same make and model for all displays within a video wall to avoid bezel and panel size discrepancies.

4. Under Receiver, which lists all the available decoders, drag and drop each decoder to its correct position within the video wall grid to the right of the list.

the name of the decoder is displayed within the selected location of the video wall and the display changes colors:

- Green – the display is assigned to the video wall and is in video wall mode.
- Red – the display is assigned but is not active/ in the correct mode.
- Blue – no display has been assigned yet.

5. Click **Save Group** to save the changes to the current video wall configuration.

6. Click **Execute** to save the changes to the current video wall configuration and then execute the changes. If the video wall is not already active, this action activates it.

Video wall is configured.

Technical Specifications

Output	1 HDMI	On a female HDMI connector
Control Ports	1 RS-232	On a 3-pin terminal block
	8 Triggers	On a 10-pin terminal block connector
	2 LAN	On RJ-45 female connectors
	1 USB 2.0	On a Type A USB connector
Video	Output Resolution	1920x1080@60Hz
	Compliance	HDCP 1.4, HDCP 2.2
Indication LED	Front Panel	Power LED
Power	Consumption	5V DC, 1.4A
	Source	5V DC, 4A
Environmental Conditions	Operating Temperature	0° to +40°C (32° to 104°F)
	Storage Temperature	-20° to +60°C (-4° to 140°F)
	Humidity	20% to 90%, RHL non-condensing
Regulatory Compliance	Safety	CE, FCC
	Environmental	RoHs, WEEE
	ESD Protection (HBM)	±8kV (Air Discharge) ±4kV (Contact Discharge)
Enclosure	Size	Special
	Type	Metal (steel)
	Cooling	Convection Ventilation
General	Net Dimensions (W, D, H)	23.1cm x 10.8cm x 2.5cm (9.1" x 4.2" x 1")
	Shipping Dimensions (W, D, H)	38.2cm x 18.8cm x 6cm (15" x 7.4" x 2.4")
	Net Weight	0.65kg (1.4lbs) approx.
	Shipping Weight	1.15kg (2.5lbs) approx.
Accessories	Included	Power adapter and cord
Specifications are subject to change without notice at www.kramerav.com		

Default Communication Parameters

RS-232	
Baud Rate:	19,200
Data Bits:	8
Stop Bits:	1
Parity:	None
IP	
LAN1	DHCP
LAN2 IP Address:	192.168.1.50
Subnet Mask:	255.255.255.0
Gateway:	192.168.1.254
User/Password:	Admin/Admin
Full Factory Reset	
Web pages	In SYSTEM page select reset options: Factory reset; reset all transmitters; reset all receivers.

Video Specifications

Supported Resolutions (Hz)	Output HDMI
720x400p@70/85	x
640x480p@60/72/75/85	x
720x480i@60	x
720x480p@60	x
720x576i@50	x
720x576p@50	x
800x600p@56/60/72/75/85	x
848x480p@60	x
1024x768p@60/70/75/85	x
1152x864p@75	x
1280x720p@50/60	x
1280x768p@60/75/85	x
1280x800p@60/75/85	x
1280x960p@60/85	x
1280x1024p@60/75/85	x
1360x768p@60	x
1366x768p@60	x
1400x1050p@60	x
1440x900p@60/75	x
1600x900p@60RB	x
1600x1200p@60	x
1680x1050p@60	x
1920x1080i@50/60	x
1920x1080p@24/25/30	x
1920x1080p@50/60	60
1920x1200p@60RB	x

Cable Length	1080p		4K30	4K60
	8-bit	12-bit	(4:4:4) 8-bit	(4:4:4) 8-bit
High Speed HDMI Cable				
HDMI Output	15m	x	x	x

Bandwidth Category Examples:

- 1080p (FHD Video)
 - Up to 1080p@60Hz, 12-bit color
 - Data rates lower than 5.3Gbps or below 225MHz TMDS clock
- 4K30 (4K UHD Video)
 - 4K@24/25/30Hz & 4K@50/60Hz (4:2:0), 8-bit color
 - Data rates higher than 5.3Gbps or above 225MHz TMDS clock but below 10.2Gbps
- 4K60 (4K UHD+ Video)
 - 4K@50/60Hz (4:4:4, 8-bit)
 - 4K@50/60Hz (4:2:0, 10-bit HDR) Data rates higher than 10.2Gbp

Acronyms

ACRONYM	COMPLETE TERM
10GbE	10 Gigabit Ethernet
ADC	Analog-to-Digital Converter
ASCII	American Standard Code for Information Interchange
AVoIP	Audio/Video over IP
AVR	Audio/Video Receiver or Recorder
Cat.5e	Enhanced Category 5 cable
Cat.6	Category 6 cable
Cat.6A	Augmented Category 6 cable
Cat.7	Category 7 cable
CLI	Command-Line Interface
DAC	Digital-to-Analog Converter
DHCP	Dynamic Host Configuration Protocol
DP	DisplayPort
EDID	Extended Display Identification Data
GbE	Gigabit Ethernet
GUI	Graphical User Interface
HDCP	High-bandwidth Digital Content Protection
HDMI	High-Definition Multimedia Interface
HDR	High Dynamic Range
HDTV	High-Definition Television
IGMP	Internet Group Management Protocol
IP	Internet Protocol
IR	Infrared
KVM	Keyboard/Video/Mouse
LAN	Local Area Network
LED	Light-Emitting Diode
LPCM	Linear Pulse-Code Modulation
MAC	Media Access Control

Telnet Control

Before attempting to use Telnet control, please ensure that both the unit and the PC are connected to the same active networks.

To Access the Command Line Interface (CLI)	
Windows 7	Click Start , type “cmd” in the search field, and press Enter .
Windows XP	Click Start > Run , type “cmd”, and press Enter .
Mac OS X	Click Go > Applications > Utilities > Terminal .

Once in the Command Line Interface (CLI) type “**telnet**” followed by the IP address of the unit (and the port number if it is non-standard) and then hit “**Enter**”. This will connect us to the unit we wish to control.

```
Microsoft Windows [Version 6.1.7601]
Copyright (c) 2009 Microsoft Corporation. All rights reserved.

C:\Users\Administrator>telnet 192.168.1.50 23
```



If the IP address is changed then the IP address required for Telnet access will also change accordingly.

This unit defaults to DHCP mode. The current IP address can be verified using the HDMI output or RS-232 if the Device Discovery software is not available.

RS-232 and Telnet Commands

The RS-232 contains the following Telnet commands:

help	get lan N1 static ipaddr	set all voip audio out oN1 route N2 N3
help N1	set lan N1 static netmask N2	set tx N1 uart 1 command [N2]
?	get lan N1 static netmask	set rx N1 uart 1 command [N2]
? N1	set lan N1 static gateway N2	set all tx uart command [N1]
get fw ver	get lan N1 static gateway	set all rx uart command [N1]
set factory default	get uart list	set voip N1 uart route N2
get command ver	set uart N1 reset	set all voip uart route N1
get model name	set uart N1 baudrate N2	set tx N1 ir 1 command [N2]
get model type	get uart N1 baudrate	set rx N1 ir 1 command [N2]
get mac N1 addr	set uart N1 stop bit N2	set all tx ir command [N1]
set factory ipconfig default	get uart N1 stop bit	set all rx ir command [N1]
set system reboot	set uart N1 data bit N2	set voip N1 ir route N2
set lan N1 ip mode N2	get uart N1 data bit	set all voip ir route N1
get lan N1 ip mode	set uart N1 parity N2	set voip N1 usb device o1 route N2 1
get lan N1 ipconfig	get uart N1 parity	set video wall preset N1
get lan N1 ipaddr	set uart 2 mode N1	set multiview preset N1
get lan N1 netmask	get uart 2 mode	set macro N1 run
get lan N1 gateway	set uart 2 command [N1]	
set lan N1 static ipaddr N2	set voip N1 audio out oN2 route N3 n4	



Commands will not be executed unless followed by a carriage return.
Commands are not case-sensitive.

help

help↵

Show the full command list.

help N1

help N1↵

Show details about the specified command.

N1 = {Command}

?

?↵

Show the full command list.

? N1

? N1↵

Show details about the specified command.

N1 = {Command}

get fw ver

get fw ver↵

Show the unit's current firmware version.

set factory default

set factory default↵

Reset the unit to the factory defaults.

get command ver

get command ver↵

Show the unit's current command version.

get model name

get model name↵

Show the unit's model name.

get model type

get model type↵

Show the unit's product type.

get mac N1 addr**get mac N1 addr**↵

Show the MAC address of the specified LAN port.

Available values for **N1**:

- 1 [LAN port 1]
- 2 [LAN port 2]

set factory ipconfig default**set factory ipconfig default**↵

Reset the unit's network settings to the factory defaults.

set system reboot**set system reboot**↵

Reboot the unit.

set lan N1 ip mode N2**set lan N1 ip mode N2**↵

Set the IP address assignment mode of the specified LAN port.

Available values for **N1**:

- 1 [LAN Port 1]
- 2 [LAN Port 2]

Available values for **N2**:

- Static [Static IP mode]
- DHCP [DHCP mode]

get lan N1 ip mode**get lan N1 ip mode**↵

Show the current IP address assignment mode of the specified LAN port.

Available values for **N1**:

- 1 [LAN Port 1]
- 2 [LAN Port 2]

get lan N1 ipconfig**get lan N1 ipconfig**↵

Show the specified LAN port's current IP configuration information.

Available values for **N1**:

- 1 [LAN Port 1]
- 2 [LAN Port 2]

get lan N1 ipaddr**get lan N1 ipaddr**↵

Show the specified LAN port's current IP address.

Available values for **N1**:

- 1 [LAN Port 1]
- 2 [LAN Port 2]

get lan N1 netmask**get lan N1 netmask**↵

Show the specified LAN port's current netmask.

Available values for **N1**:

- 1 [LAN Port 1]
- 2 [LAN Port 2]

get lan N1 gateway**get lan N1 gateway**↵

Show the specified LAN port's current gateway address.

Available values for **N1**:

- 1 [LAN Port 1]
- 2 [LAN Port 2]

set lan N1 static ipaddr N2**set lan N1 static ipaddr N2**↵

Set the specified LAN port's static IP address.

Available values for **N1**:

- 1 [LAN Port 1]
- 2 [LAN Port 2]

N2 = X.X.X.X [X = 0-255, IP address]**get lan N1 static ipaddr****get lan N1 static ipaddr**↵

Show the specified LAN port's current static IP address.

Available values for **N1**:

- 1 [LAN Port 1]
- 2 [LAN Port 2]

set lan N1 static netmask N2**set lan N1 static netmask N2**↵

Set the specified LAN port's static netmask.

Available values for **N1**:

1 [LAN Port 1]

2 [LAN Port 2]

N2 = X.X.X.X [X = 0~255, netmask]**get lan N1 static netmask****get lan N1 static netmask**↵

Show the specified LAN port's current static netmask.

Available values for **N1**:

1 [LAN Port 1]

2 [LAN Port 2]

set lan N1 static gateway N2**set lan N1 static gateway N2**↵

Set the specified LAN port's static gateway address.

Available values for **N1**:

1 [LAN Port 1]

2 [LAN Port 2]

N2 = X.X.X.X [X = 0~255, gateway address]**get lan N1 static gateway****get lan N1 static gateway**↵

Show the specified LAN port's current static gateway address.

Available values for **N1**:

1 [LAN Port 1]

2 [LAN Port 2]

get uart list**get uart list**↵

List all available serial ports.

set uart N1 reset**set uart N1 reset**↵

Reset the specified serial port's settings to the factory defaults.

Available values for **N1**:

1 [3-pin serial port]

2 [5-pin serial port]

set uart N1 baudrate N2

set uart N1 baudrate N2↵

Set the baud rate of the specified serial port.

Available values for **N1**:

- 1 [3-pin serial port]
- 2 [5-pin serial port]

Available values for **N2**:

- 2400 [2400 baud]
- 4800 [4800 baud]
- 9600 [9600 baud]
- 19200 [19200 baud]
- 38400 [38400 baud]
- 57600 [57600 baud]
- 115200 [115200 baud]

get uart N1 baudrate

get uart N1 baudrate↵

Show the current baud rate of the specified serial port.

Available values for **N1**:

- 1 [3-pin serial port]
- 2 [5-pin serial port]

set uart N1 stop bit N2

set uart N1 stop bit N2↵

Set the number of stop bits for the specified serial port.

Available values for **N1**:

- 1 [3-pin serial port]
- 2 [5-pin serial port]

Available values for **N2**:

- 1 [1 stop bit]
- 2 [2 stop bits]

get uart N1 stop bit

get uart N1 stop bit↵

Show the current number of stop bits for the specified serial port.

Available values for **N1**:

- 1 [3-pin serial port]
- 2 [5-pin serial port]

set uart N1 data bit N2

set uart N1 data bit N2↵

Set the data bits used by the specified serial port.

Available values for **N1**:

- 1 [3-pin serial port]
- 2 [5-pin serial port]

Available values for **N2**:

- 7 [7 data bits]
- 8 [8 data bits]

get uart N1 data bit

get uart N1 data bit↵

Show the current number of data bits used by the specified serial port.

Available values for **N1**:

- 1 [3-pin serial port]
- 2 [5-pin serial port]

set uart N1 parity N2

set uart N1 parity N2↵

Set the parity of the specified serial port.

Available values for **N1**:

- 1 [3-pin serial port]
- 2 [5-pin serial port]

Available values for **N2**:

- 0 [None]
- 1 [Odd]
- 2 [Even]

get uart N1 parity

get uart N1 parity↵

Show the current parity setting of the specified serial port.

Available values for **N1**:

- 1 [3-pin serial port]
- 2 [5-pin serial port]

set uart 2 mode N1

set uart 2 mode N1↵

Set the operational mode of the Control Output (5-pin) serial port. Available values for **N1**:

- 0 [Disabled]
- 1 [RS-232 mode]
- 2 [RS-422 mode]
- 3 [RS-485 mode]

get uart 2 mode

get uart 2 mode↵

Show the current operational mode of the Control Output (5-pin) serial port.

set uart 2 command [N1]

set uart 2 command [N1]↵

Transmit the specified command data via the Control Output (5-pin) serial port.

N1 = {Command data} [ASCII text]

Note: To transmit hex data, each ASCII hex pair (octet) must be preceded by “\x”. For example a carriage return would be “\x0D”.

set voip N1 audio out oN2 route N3 n4

set voip N1 audio out oN2 route N3 n4↵

Route the specified transmitter’s audio input to the specified receiver’s audio output.

N1 = rx1~rx128 [Receiver device ID]

Available values for **N2**:

1 [HDMI audio output]

2 [Analog audio output]

N3 = tx1~tx128 [Transmitter device ID]

Available values for **N4**:

1 [HDMI audio input]

2 [Analog audio input]

*Note: The values for **N2** and **N4** must match.*

set all voip audio out oN1 route N2 N3

set all voip audio out oN1 route N2 N3↵

Route the specified transmitter’s audio input to all receivers’ audio outputs.

Available values for **N1**:

1 [HDMI audio output]

2 [Analog audio output]

N2 = tx1~tx128 [Transmitter device ID]

Available values for **N3**:

1 [HDMI audio input]

2 [Analog audio input]

*Note: The values for **N1** and **N3** must match.*

set tx N1 uart 1 command [N2]**set tx N1 uart 1 command [N2]**↵

Transmit the specified command data via the serial port on the specified transmitter.

N1 = 1~128..... [Transmitter device ID]

N2 = {Command data} [ASCII text]

Note: To transmit hex data, each ASCII hex pair (octet) must be preceded by “\x”. For example a carriage return would be “\x0D”.

set rx N1 uart 1 command [N2]**set rx N1 uart 1 command [N2]**↵

Transmit the specified command data via the serial port on the specified receiver.

N1 = 1~128..... [Receiver device ID]

N2 = {Command data} [ASCII text]

Note: To transmit hex data, each ASCII hex pair (octet) must be preceded by “\x”. For example a carriage return would be “\x0D”.

set all tx uart command [N1]**set all tx uart command [N1]**↵

Transmit the specified command data via the serial port on all transmitters.

N1 = {Command data} [ASCII text]

Note: To transmit hex data, each ASCII hex pair (octet) must be preceded by “\x”. For example a carriage return would be “\x0D”.

set all rx uart command [N1]**set all rx uart command [N1]**↵

Transmit the specified command data via the serial port on all receivers.

N1 = {Command data} [ASCII text]

Note: To transmit hex data, each ASCII hex pair (octet) must be preceded by “\x”. For example a carriage return would be “\x0D”.

set voip N1 uart route N2**set voip N1 uart route N2**↵

Route the specified transmitter or receiver’s serial port Rx pin to the serial port Tx pin on the specified transmitter or receiver.

Available values for **N1**:

tx1~tx128 [Transmitter device ID (Tx pin)]

rx1~rx128 [Receiver device ID (Tx pin)]

Available values for **N2**:

tx1~tx128 [Transmitter device ID (Rx pin)]

rx1~rx128 [Receiver device ID (Rx pin)]

set all voip uart route N1

set all voip uart route N1 ←

Route the specified transmitter or receiver's serial port Rx pin to all AVoIP devices' serial port Tx pins.

Available values for **N1**:

tx1~tx128 [Transmitter device ID]

rx1~rx128 [Receiver device ID]

set tx N1 ir 1 command [N2]

set tx N1 ir 1 command [N2] ←

Transmit the specified IR data via the IR output on the specified transmitter.

N1 = 1~128..... [Transmitter device ID]

N2 = {IR ASCII hex data}.. [Pronto format IR data]

set rx N1 ir 1 command [N2]

set rx N1 ir 1 command [N2] ←

Transmit the specified IR data via the IR output on the specified receiver.

N1 = 1~128..... [Receiver device ID]

N2 = {IR ASCII hex data}.. [Pronto format IR data]

set all tx ir command [N1]

set all tx ir command [N1] ←

Transmit the specified IR data via the IR outputs on all transmitters.

N1 = {IR ASCII hex data}.. [Pronto format IR data]

set all rx ir command [N1]

set all rx ir command [N1] ←

Transmit the specified IR data via the IR outputs on all receivers.

N1 = {IR ASCII hex data}.. [Pronto format IR data]

set voip N1 ir route N2

set voip N1 ir route N2 ←

Route the specified transmitter or receiver's IR input to the IR output on the specified transmitter or receiver.

Available values for **N1**:

tx1~tx128 [Transmitter device ID (IR output)]

rx1~rx128 [Receiver device ID (IR output)]

Available values for **N2**:

tx1~tx128 [Transmitter device ID (IR input)]

rx1~rx128 [Receiver device ID (IR input)]

set all voip ir route N1

set all voip ir route N1 ↵

Route the specified transmitter or receiver's IR input to all AVoIP devices' IR outputs.

Available values for **N1**:

tx1~tx128[Transmitter device ID (IR input)]

rx1~rx128[Receiver device ID (IR input)]

set voip N1 usb device o1 route N2 1

set voip N1 usb device o1 route N2 1 ↵

Route the specified AVoIP device's USB device to the specified AVoIP device's USB host.

Available values for **N1**:

tx1~tx128[Transmitter device ID (USB device)]

rx1~rx128[Receiver device ID (USB device)]

Available values for **N2**:

tx1~tx128[Transmitter device ID (USB host)]

rx1~rx128[Receiver device ID (USB host)]

set video wall preset N1

set video wall preset N1 ↵

Execute the specific video wall configuration.

N1 = 1~128..... [Video wall group ID]

set multiview preset N1

set multiview preset N1 ↵

Execute the specific multiview preset.

N1 = 1~128..... [Multiview preset ID]

set macro N1 run

set macro N1 run ↵

Execute the specified macro immediately.

N1 = 1~16..... [Macro ID]



P/N: 2900-301456



Rev: 1



SAFETY WARNING

Disconnect the unit from the power supply before opening and servicing

For the latest information on our products and a list of Kramer distributors, visit our website where updates to this user manual may be found.

We welcome your questions, comments, and feedback.

The terms HDMI, HDMI High-Definition Multimedia Interface, and the HDMI Logo are trademarks or registered trademarks of HDMI Licensing Administrator, Inc. All brand names, product names, and trademarks are the property of their respective owners.